



# IRON MAN

## Seamless Rollformers

Operating and Maintenance  
Troubleshooting Guide



MADE IN THE USA



*Get the app!*





In purchasing a KWM Gutterman Inc. gutter-forming machine, you are welcomed to the growing group of people who recognize quality and precision. KWM is proud of our modern facility and highly trained personnel that allow KWM Gutterman Inc. to manufacture the very best roll-forming equipment.

The operating and maintenance guide explains the features of your new KWM Gutterman Inc. gutter machine. Please read it and follow the instructions carefully.

As the manufacturer of your roll-forming machine, KWM wants you to be completely satisfied with your purchase. The maintenance and troubleshooting guide is designed to help answer most questions or concerns on your roll-forming machine. A copy of our warranty is included in our maintenance guide.

“Manufacturing the Best, Built to Stand the Test”

Please visit us at [www.kwmgutterman.com](http://www.kwmgutterman.com) for product information.

Our family business will only succeed by making you, our customer, our top priority! We are only a phone call or a click away.

1- 888-729-4290  
[sales@kwmgutterman.com](mailto:sales@kwmgutterman.com)

Thank you for your purchase!

At Your Service, We Remain.

Kenneth W. Minor Sr.  
Keith W. Minor Sr.

## TABLE OF CONTENTS

SECTION		PAGE #
1	IRONMAN & JUNIOR MACHINE SPECIFICATIONS	3
2	MACHINE SAFETY AND GENERAL MAINTENANCE	4
3	MACHINE MOUNTING	4
4	5" GUTTER MACHINE ORIENTATION	5
4D	IRONMAN 5" GUTTER MACHINE DRAWING	6
4A	6" GUTTER MACHINE ORIENTATION	7
4AD	IRONMAN 6" GUTTER MACHINE DRAWING	8
5	MACHINE ELECTRICAL CONTROLS, OPERATOR PANELS, AND BASIC FEEDING OPERATION	9
5D	MACHINE WIRING DIAGRAMS	10-17
6	MACHINE ELECTRICAL CORD REQUIREMENTS	9
7	SPOOL UPRIGHT SUPPORTS	18
8	SPOOL ASSEMBLY AND LOADING COIL	18
7D	SPOOL & UPRIGHT ASSEMBLY	19
9	CRADLE OVERVIEW	20
10	CRADLE ASSEMBLY AND LOADING COIL	20
9D	CRADLE ASSEMBLY	21
11	ENTRANCE GUIDE SYSTEM	22
11D	ENTRANCE GUIDE ASSEMBLY	23
12	CRANK ENTRANCE GUIDE SYSTEM	24
13	POLYURETHANE DRIVE SYSTEM	26
14	FORMING COMPONENTS AND ASSEMBLIES	27
15	LIP FORMING BOX (FORMS THE LIP PORTION OF THE GUTTER)	28
16	EXIT END FORMING AND DRIVE ASSEMBLY	31
17	BEAD ROLLER ASSEMBLY	34
18	GUILLOTINE AND FACE PLATE ASSEMBLY	35
19	BASIC MACHINE SETUP AND DIMENSIONS	37
20	GUTTER TALK	39
21	MACHINE OPERATION RECAP AND SUMMARY	40
22	ANALYZING GUTTER	40
23	TROUBLESHOOTING	41
24	DRAWINGS OF GUTTER PROFILE	43
25	WARRANTY INFORMATION	45
26	CONTACT INFORMATION	46

**WARNING:**

**USE A 5,000 WATT GENERATOR MINIMUM**

# **SECTION: 1**

## **GUTTER MACHINE SPECIFICATIONS**

**POWER:** ¾ HP, 110 V, 60 HTZ SINGLE PHASE TEFC MOTOR, 13.6 AMP.  
 ¾ HP, 110 V, 50 HTZ SINGLE PHASE TEFC MOTOR, 13.6 AMP.  
 ¾ HP, 220 V, 50 HTZ SINGLE PHASE TEFC MOTOR, 6.8 AMP.

### **JUNIOR MACHINES**

	<b>6" JUNIOR</b>	<b>COMBO JUNIOR</b>
LENGTH:	107.5" (273.1 cm)	107.5" (273.1 cm)
HEIGHT:	48" (122 cm)	48" (122 cm)
WIDTH:	24" (61 cm)	24" (61 cm)
APPROXIMATE WEIGHT:	960 lbs (435.4 kg)	1075 lbs (487.6 kg)

### **IRONMAN MACHINES**

	<b>5" IRONMAN</b>	<b>6" IROMAN</b>	<b>COMBO IRONMAN</b>	<b>7" IRONMAN</b>
LENGTH:	98.5" (250.2 cm)	122" (309.88 cm)	122" (309.88 cm)	149" (378.46 cm)
HEIGHT:	48" (122 cm)	48" (122 cm)	48" (122 cm)	48" (122 cm)
WIDTH:	24" (61 cm)	24" (61 cm)	24" (61 cm)	24" (61 cm)
APPROXIMATE WEIGHT:	1100 lbs (499 kg)	1300 lbs (589.7 kg)	1400 lbs (635 kg)	1490 lbs (675.85 kg)

**DRIVE:** Powered by polyurethane drive rollers via chain and sprockets

**SHEAR:** Front pull guillotine style shear

**SPEED:** APPROX. 35 ft. per minute

**CONTROLS:** Push-button entry/exit end manual controls  
 with JOG feature & power interruption safety wiring

**MATERIAL WIDTH:** 5" Gutter Machine: 11-¾" to 12-3/8"  
 6" Gutter Machine: 15"  
 7" Gutter Machine: 18"

### **RECOMMENDED MATERIAL JUNIOR MACHINES**

ALUMINUM - MAX .032 THK  
 COPPER - 16 OZ to 20 OZ. MINIMUM ¾ HARD

### **RECOMMENDED MATERIAL IRONMAN MACHINES**

PAINTED STEEL - MAX 24 GAUGE  
 ALUMINIZED STEEL - MAX 24 GAUGE  
 TERNECOAT STEEL - MAX 24 GAUGE  
 ALUMINUM - MAX .032 THK  
 COPPER - 16 OZ. to 20 OZ. MINIMUM ½ HARD



## **SECTION: 4**

### **5" GUTTER MACHINE ORIENTATION**

For communication purposes in the manual, the machine orientation is as follows: (SEE PG. 5 & 6)

**A. ENTRANCE**

The ENTRANCE of the machine is where the forming process begins and where the material is fed.

**B. EXIT**

The EXIT of the machine is where the forming process is complete and where the finished gutter exits the machine.

**C. RIGHT SIDE**

The RIGHT SIDE is determined by facing the entrance end of the machine.

The RIGHT SIDE of the machine is where the O.G or face side gutter is formed.

**COMPONENTS ON RIGHT SIDE:**

1. O.G. FACE GUIDE SHOE (RIGHT SHOE)
2. O.G. FACE GUIDE BAR ASSEMBLY
3. O.G. FACE FORMING BOX ASSEMBLY
4. O.G. FACE LIP FORMING BOX ASSEMBLY
5. O.G. FACE BELL ROLLER

**D. LEFT SIDE**

The LEFT SIDE is determined by facing the entrance end of the machine.

The LEFT SIDE of the machine is where the back of the gutter is formed.

**COMPONENTS ON LEFT SIDE:**

6. BACK GUIDE SHOE (LEFT SHOE)
7. BACK GUIDE BAR ASSEMBLY
8. MOTOR AND GEAR BOX
9. BACK BELL EXIT ROLLER
10. BEAD ROLLER ASSEMBLY

**E. CENTER of MACHINE**

The CENTER of the machine forms the bottom section of gutter- drive assembly.

**COMPONENTS IN CENTER OF MACHINE**

11. #1 SKATE ASSEMBLY
12. #1 DRIVE ASSEMBLY
13. #2 SKATE ASSEMBLY
14. #2 DRIVE ASSEMBLY
15. #3 SKATE ASSEMBLY
16. #3 TOP & BOTTOM DRIVE FORMING STATION
17. GUILLOTINE ASSEMBLY

# IRONMAN 5" GUTTER MACHINE

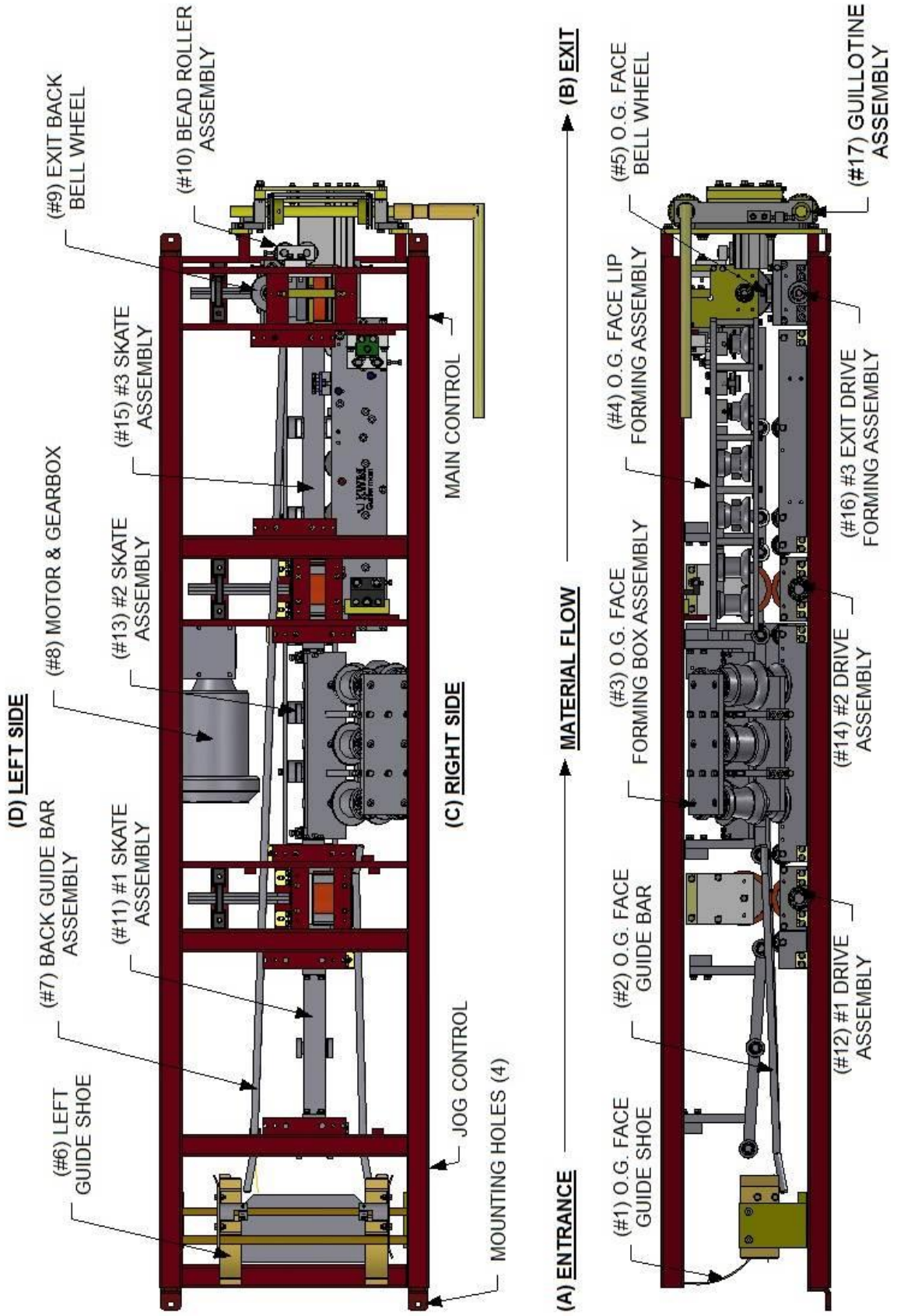

# **SECTION: 4A**

## **6” GUTTER MACHINE ORIENTATION**

For communication purposes in the manual, the machine orientation is as follows: (SEE PG. 7 & 8)

**A. ENTRANCE**

The ENTRANCE is where the forming process begins and where the material is fed.

**B. EXIT**

The EXIT is where the forming process is complete and where the finished gutter exits the machine.

**C. RIGHT SIDE**

The RIGHT SIDE of the machine is determined by facing the entrance end of machine.

The RIGHT SIDE of the machine is where the O.G or face side of gutter is formed.

**COMPONENTS ON RIGHT SIDE:**

1. O.G. FACE GUIDE SHOE (RIGHT SHOE)
2. O.G. FACE GUIDE BAR ASSEMBLY
3. O.G. FACE FORMING BOX ASSEMBLY
4. O.G. FACE LIP FORMING BOX ASSEMBLY
5. O.G. FACE BELL ROLLER

**D. LEFT SIDE**

The LEFT SIDE of the machine is determined by facing the entrance end of machine.

The LEFT SIDE of the machine is where the back of the gutter is formed.

**COMPONENTS ON LEFT SIDE:**

6. BACK GUIDE SHOE (LEFT SHOE)
7. BACK GUIDE BAR ASSEMBLY
8. MOTOR AND GEAR BOX
9. EXIT BACK BELL ROLLER
10. BEAD ROLLER ASSEMBLY

**E. CENTER of MACHINE**

The CENTER of the machine forms bottom section of gutter- drive assembly.

**COMPONENTS IN CENTER OF MACHINE:**

11. #1 SKATE ASSEMBLY
12. #1 DRIVE ASSEMBLY
- 11A. #1A SKATE ASSEMBLY
- 12A. #1A DRIVE ASSEMBLY
13. #2 SKATE ASSEMBLY
14. #2 DRIVE ASSEMBLY
15. #3 SKATE ASSEMBLY
16. #3 TOP & BOTTOM DRIVE FORMING STATION
17. GUILLOTINE ASSEMBLY

**NOTES:**

---

---

---

---

---

---

---

# IRONMAN 6" GUTTER MACHINE

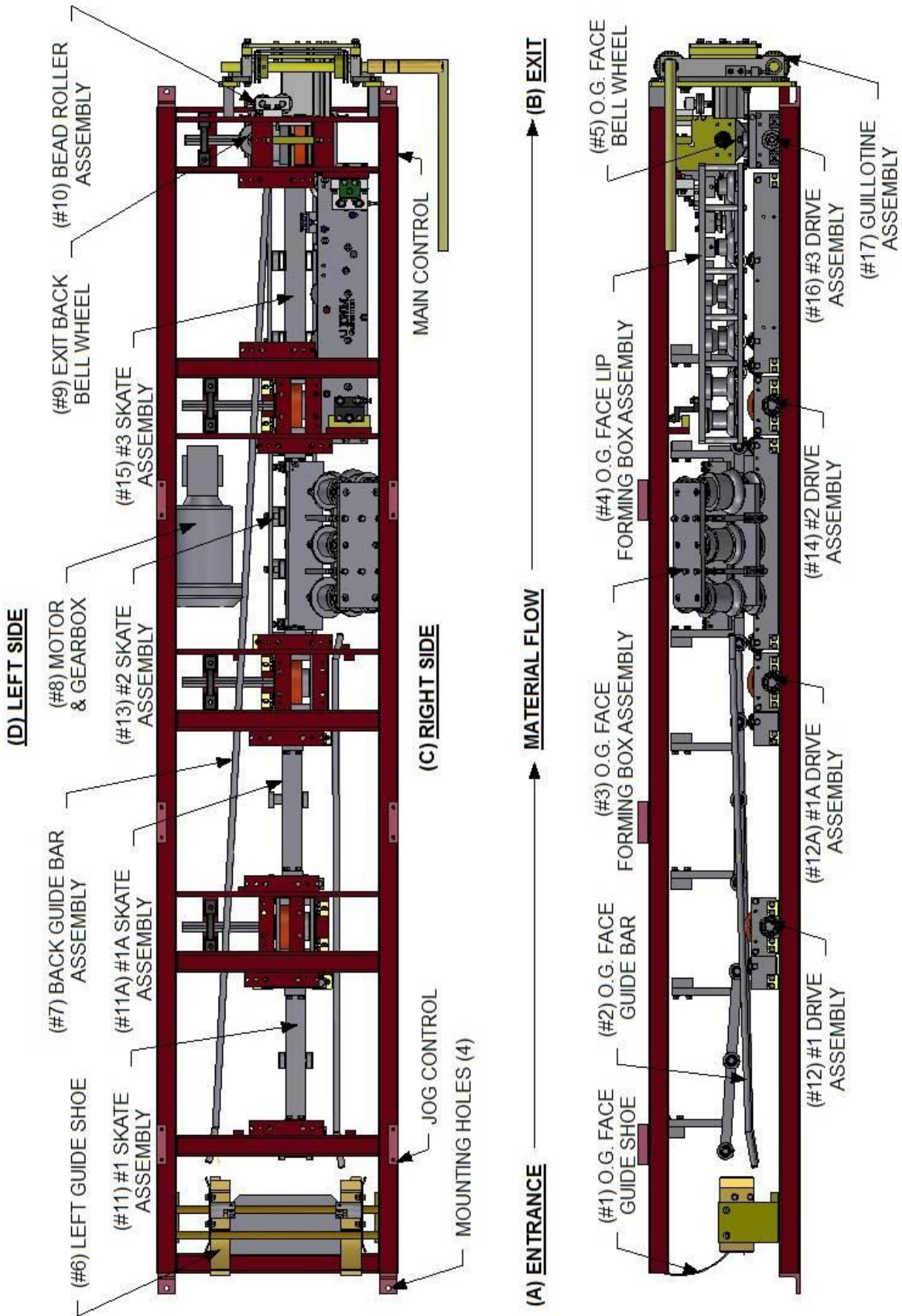

## SECTION: 5

### ELECTRICAL SYSTEM AND CONTROL LOCATIONS FEEDING THE MACHINE

**1E. MAIN OPERATOR'S PANEL**

The MAIN OPERATOR'S PANEL is located on the right side at the exit end of the machine.

**THE MAIN OPERATOR'S PANEL CONSISTS OF:**

- 2 SELECTOR SWITCHES
  - JOG-RUN
  - FORWARD-REVERSE
- 2 PUSH BUTTONS
  - START (GREEN)
  - STOP (RED)
- DUPLEX RECEPTACLE
  - ACCESSORY POWER SUPPLY

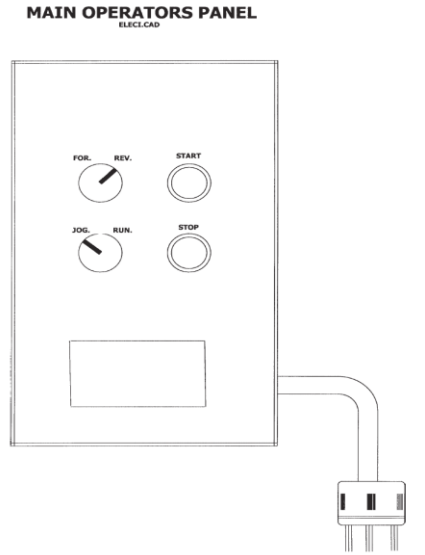

**2E. ENTRY OPERATOR'S PANEL**

The ENTRY OPERATOR'S PANEL is located on the right side at the entrance end of the machine.

**THE ENTRY OPERATOR'S PANEL CONSISTS OF:**

- 1 PUSH BUTTON
  - JOG (GREEN)
- POWER SHUT OFF
  - EMERGENCY STOP BUTTON (RED)

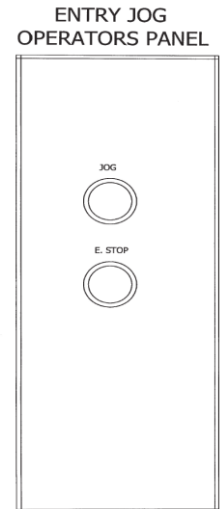

**3E. POWER SOURCE PLUG**

The POWER SOURCE PLUG is located at the exit end of the machine on the right side.

**FEEDING THE MACHINE:**

1. Position selector switch to the JOG position.
2. Position selector switch to the FORWARD position.
3. Remove pressure on spool brakes. (SEE PG. 13 DETAIL A)
4. Trim both corners of the coil material, removing two 3" X 3" triangles. (SEE PG. 15)
5. Standing at entrance of machine, position material through the entrance guides to the #1 drive assembly.
6. Activate the JOG button using your right hand-at the same time- using your left hand to push material so as to engage with #1 drive assembly. Jog the material approximately two feet.
7. Using the main control panel jog material through guillotine using START-push button.
8. Position selector switch to the RUN position.

## SECTION: 6

### ELECTRICAL CORD REQUIREMENTS

It is important to adhere to the motor manufacturer's minimum wire gage in order to maintain the warranty on the motor.

0-25'	12 ga
25-50'	10 ga
50-100'	10 ga

# IRONMAN 110V - PUSH BUTTON WIRING DIAGRAM

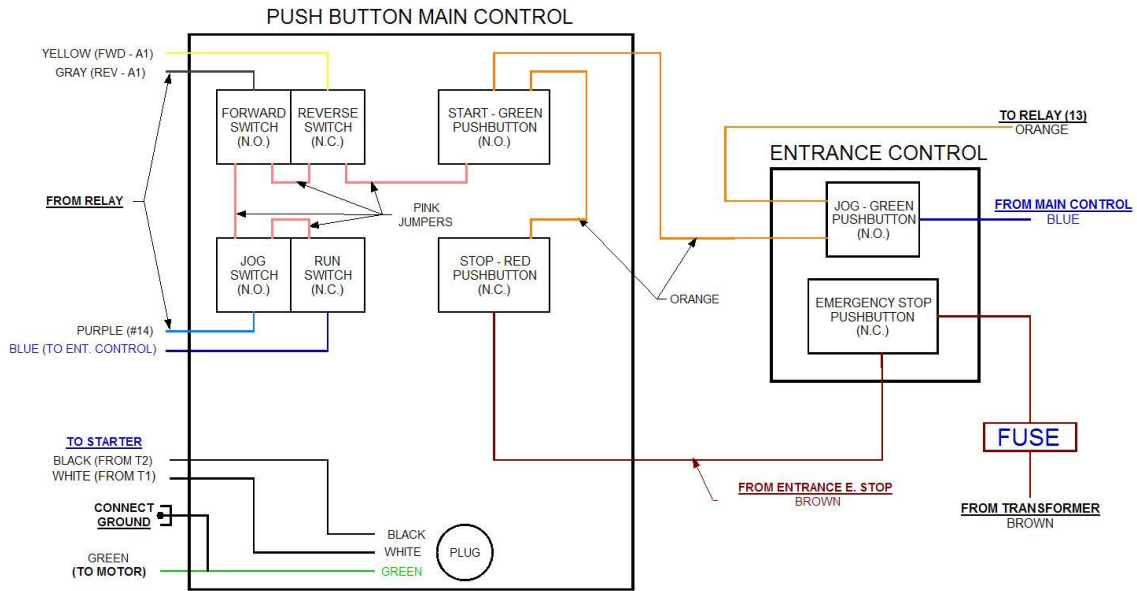

# IRONMAN 110V - WIRING DIAGRAM

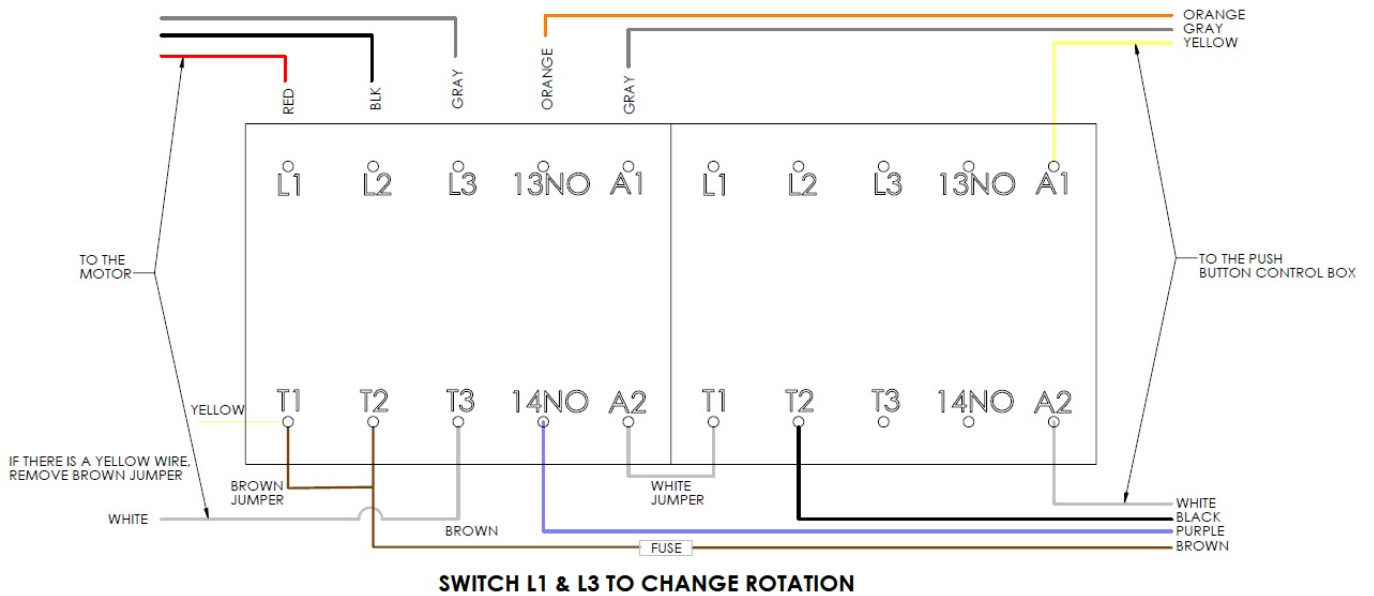

# IRONMAN 220V - PUSH BUTTON WIRING DIAGRAM

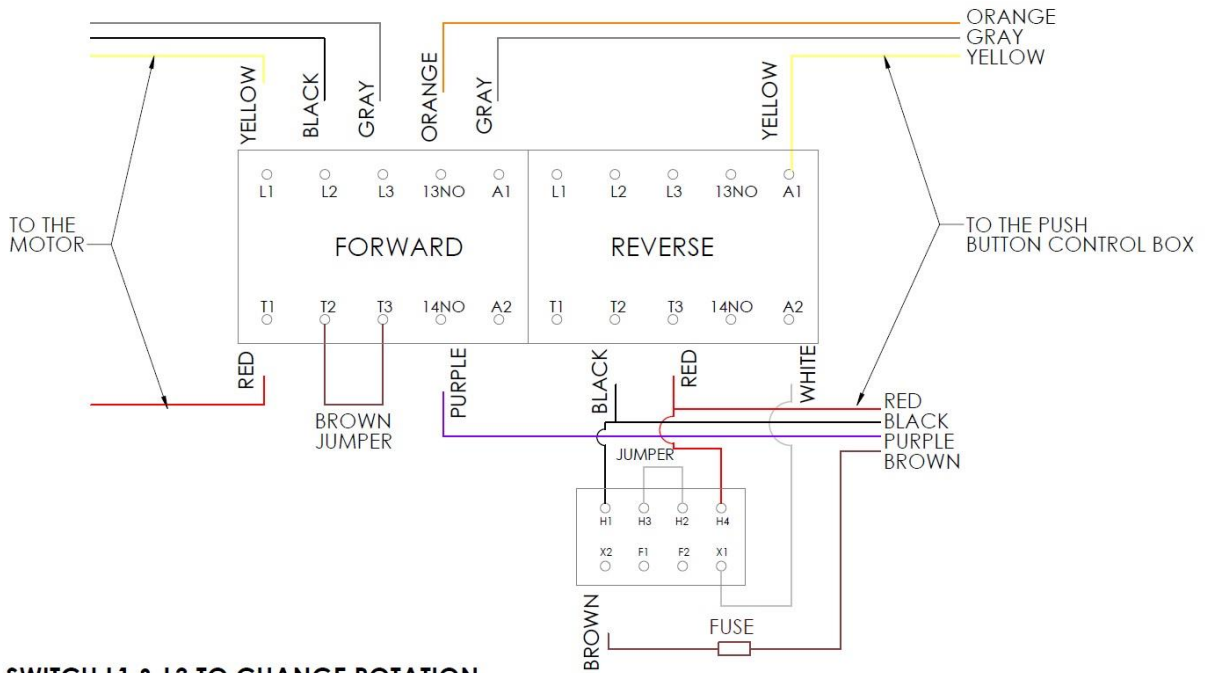
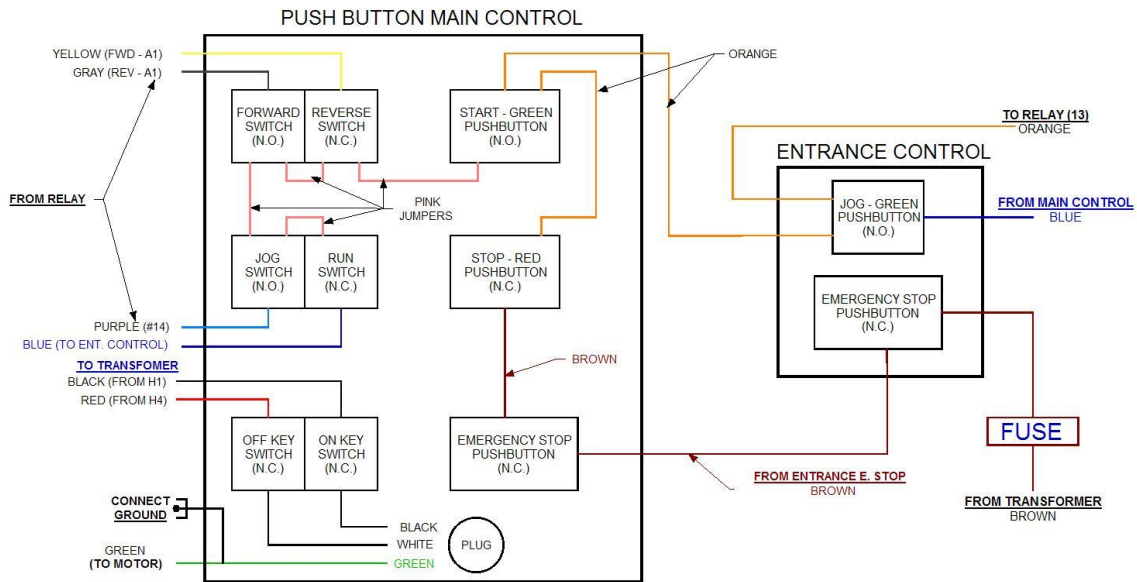

# IRONMAN 12V PUSH BUTTON WIRING DIAGRAM

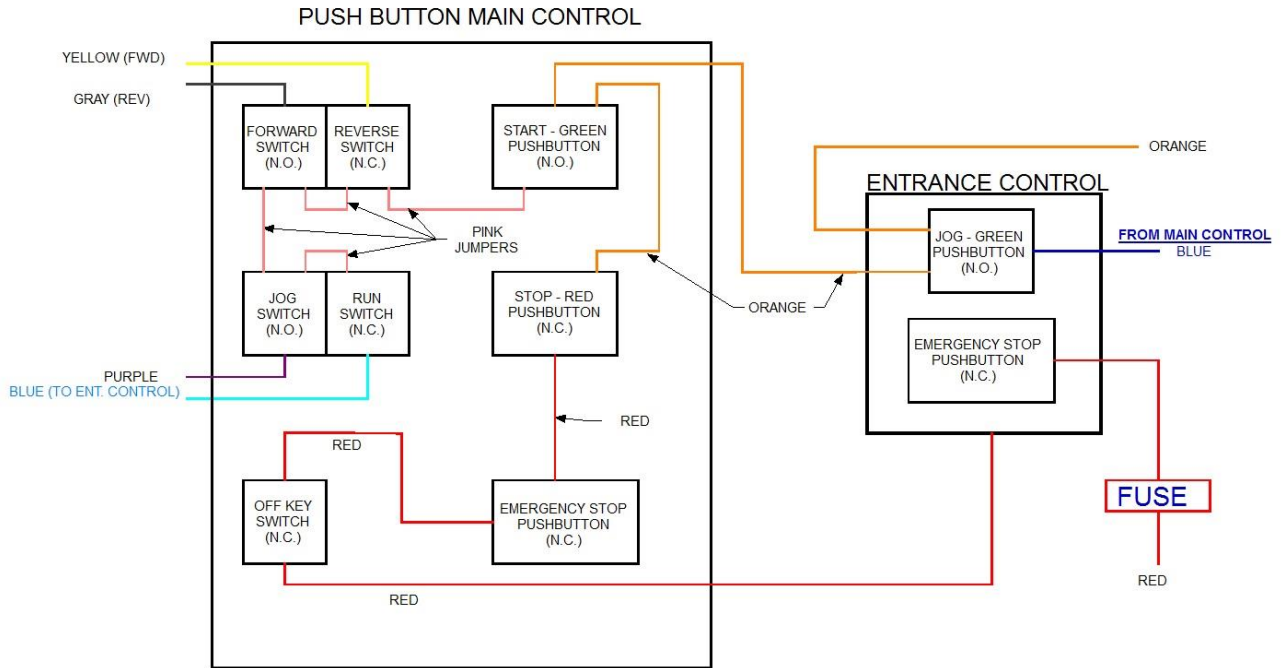

# PANTHER & IRONMAN 12V WIRING DIAGRAM

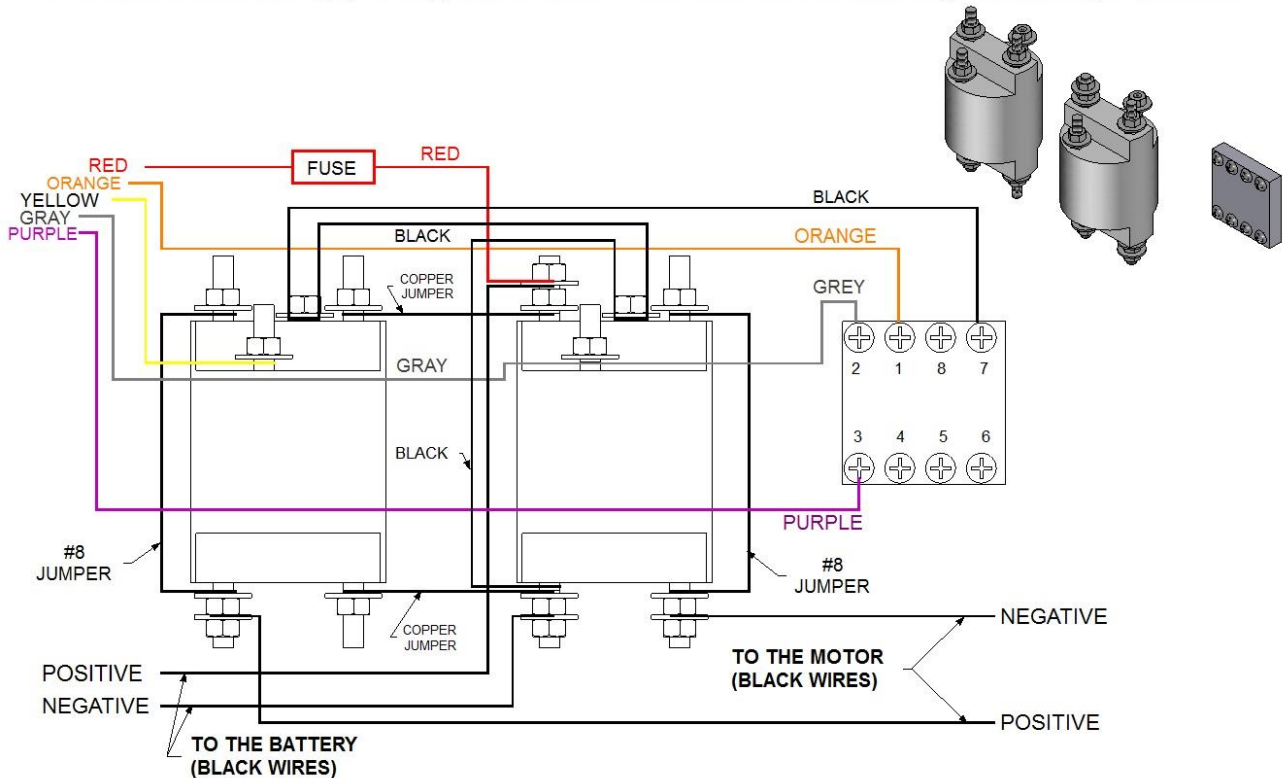

# SMART MACHINE CONTROL PANEL

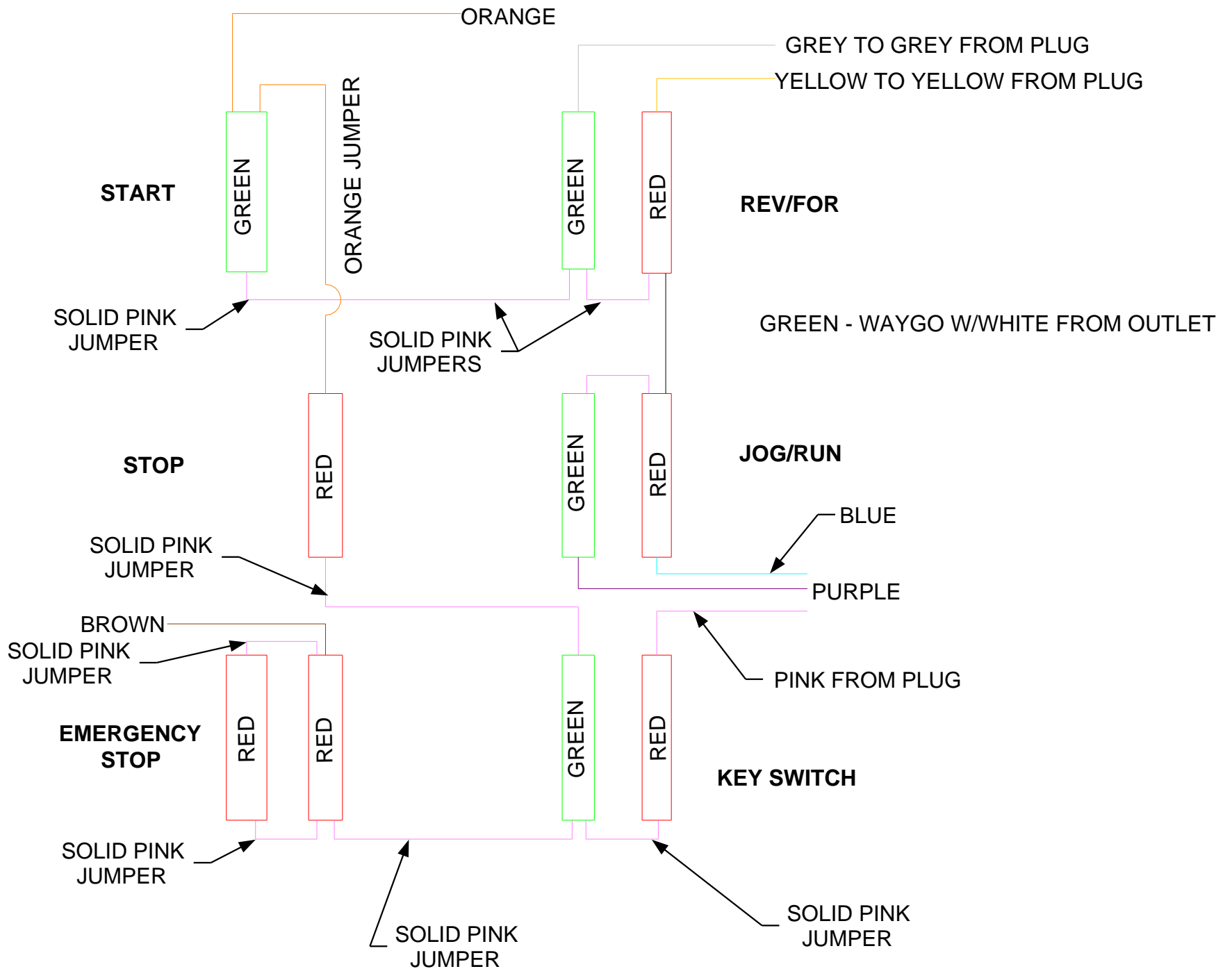

# SMART MACHINE ENTRANCE CONTROL PANEL

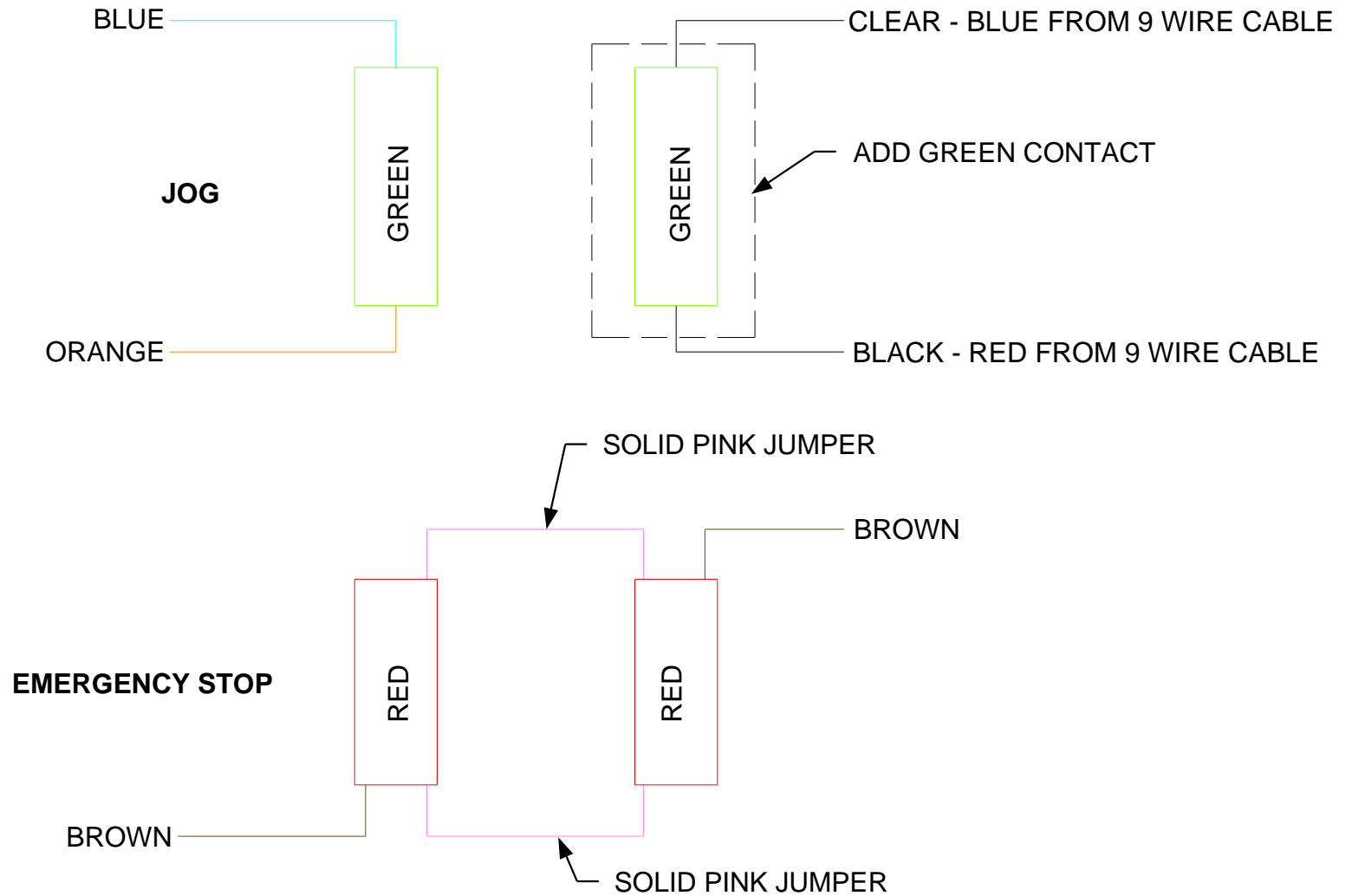

# SMART MACHINE MOTOR STARTER

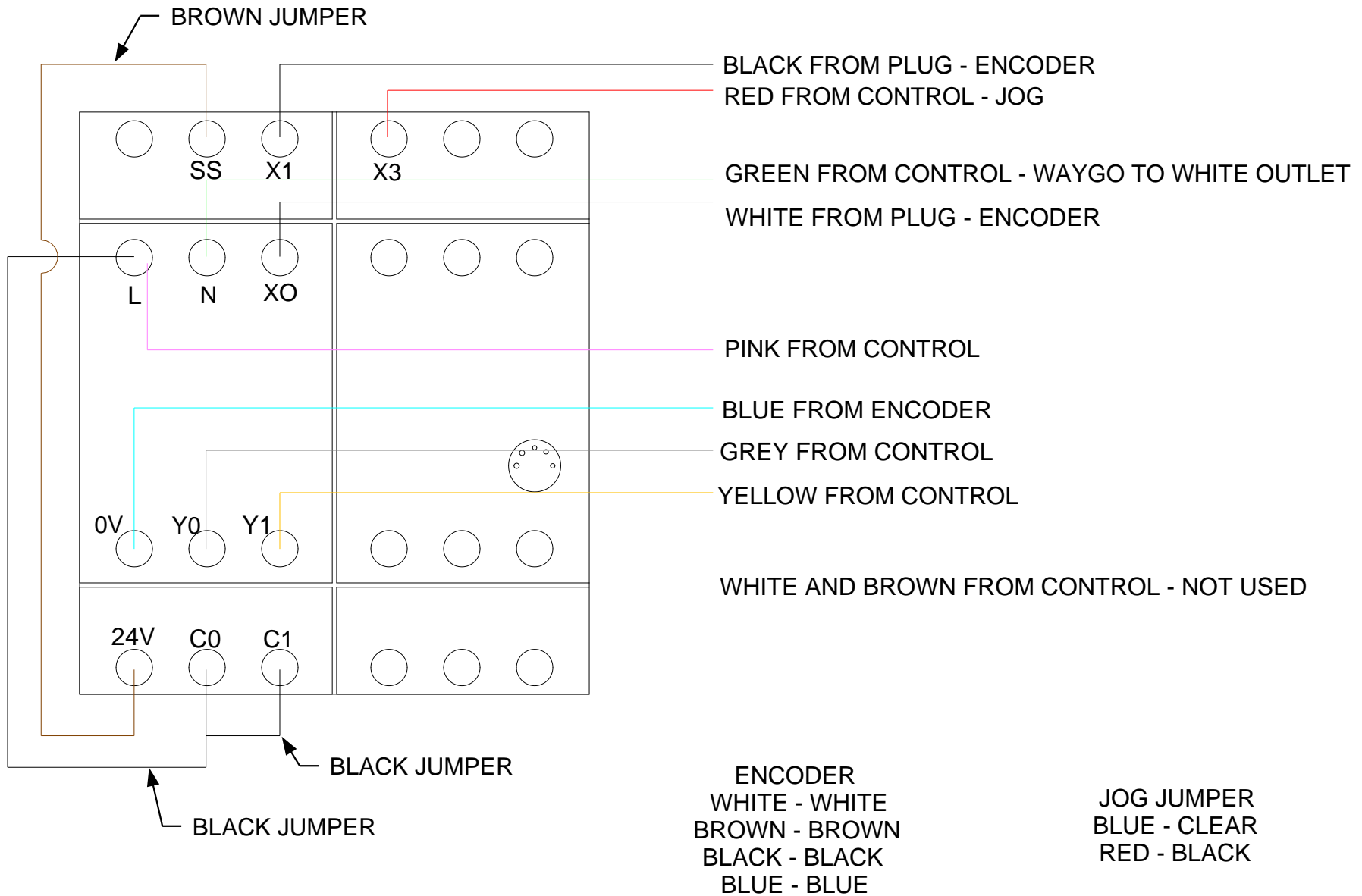

### WIRING CONNECTIONS FOR KWM MOTOR 110v 60hz LEESON MOTOR

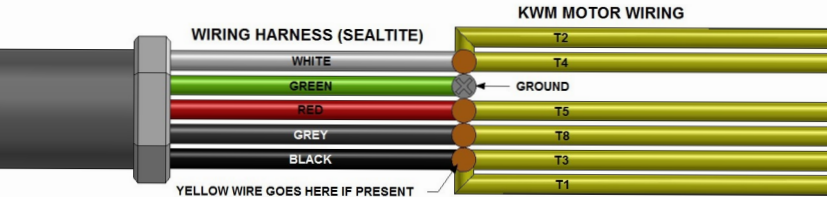

### WIRING CONNECTIONS FOR KWM MOTOR 110v 60hz BALDOR & DAYTON MOTORS

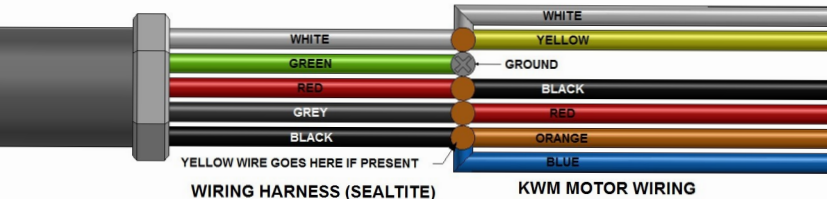

# WIRING CONNECTIONS FOR KWM MOTOR 220V

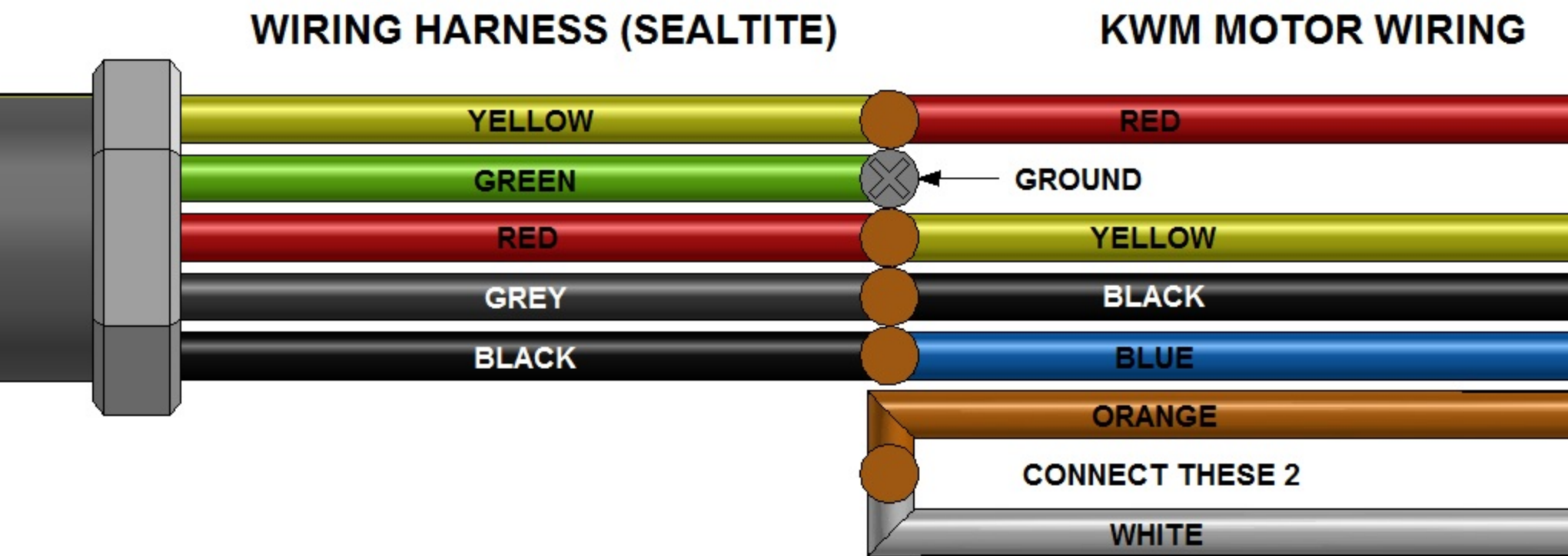

## **SECTION: 7**

### **SPOOL UPRIGHT SUPPORTS**

The IRONMAN TURNSTILE UPRIGHT is a modular turnstile support used to hold coil. Your machine may have up to three uprights.

**ONE TURNSTILE UPRIGHT ASSEMBLY CONSISTS OF:** (SEE PG. 13)

TURNSTILE UPRIGHT (1)	UPRIGHT BRAKE (2)
BASE PLATE (1)	LOCK THUMB SCREW (1)
TURNSTILE LOCKING PIN (1)	SAFETY PIN (2)
BRAKE THUMB SCREW (2)	LOCK BLOCK (1)
WING NUT (1)	

**TO ROTATE TURNSTILE FOR TWO-SIDED COIL:**

1. Loosen WING NUT loosen LOCK THUMB SCREW.
2. Slide LOCK BLOCK outward.
3. Rotate TURNSTILE 180 degrees.
4. Slide LOCK BLOCK inward.
5. Tighten LOCK THUMB SCREW then tighten WING NUT.

## **SECTION: 8**

### **SPOOL ASSEMBLY AND LOADING COIL**

**ONE SPOOL ASSEMBLY CONSISTS OF:** (SEE PG. 13)

SPOOL SHAFT (1)	SPOOL HALF (2)	5/16" QUICK RELEASE PIN (2)
-----------------	----------------	-----------------------------

**TO LOAD COIL ONTO SPOOL ASSEMBLY:**

1. Remove Safety Pins, Loosen Thumb Screws, Release the safety brakes.
2. Place the empty spool assembly on the ground or on a flat surface.
3. Remove one of the 5/16" quick release pins.
4. Slide the spool half off of the 1/4" spool shaft.
5. Insert the spool shaft through the center of the coil.
6. Replace spool half on the spool shaft, and reinstall the 5/16" quick release pin.
7. Install loaded spool assembly onto the upright. Use of mechanical lifting device recommended.
8. Engage Safety Brakes; lightly tighten thumb screws And Install Safety Pins.

**NOTE:** The spool assembly is adjustable to accept both 5" gutter material (11 3/4" – 12") and 6" gutter material (15").

**PLACING SPOOL & COIL IN THE UPRIGHT:**

Use an approved lifting device in the designated spool lifting area to position the spool assembly into the turnstile upright. ***(IMPORTANT! – Please read PRECAUTIONS)***

**PRECAUTIONS:**

- Make sure loading area is clean and clear of debris.
- Make sure Turnstile Locking Pin is securely installed.
- Always wear protective footwear when handling coil.
- Never load coil with the brake in closed position.
- Never operate machine without first checking brake & pin positions.
- Never transport machine without locking brake in closed position and safety pins installed.

# SPOOL & UPRIGHT ASSEMBLY

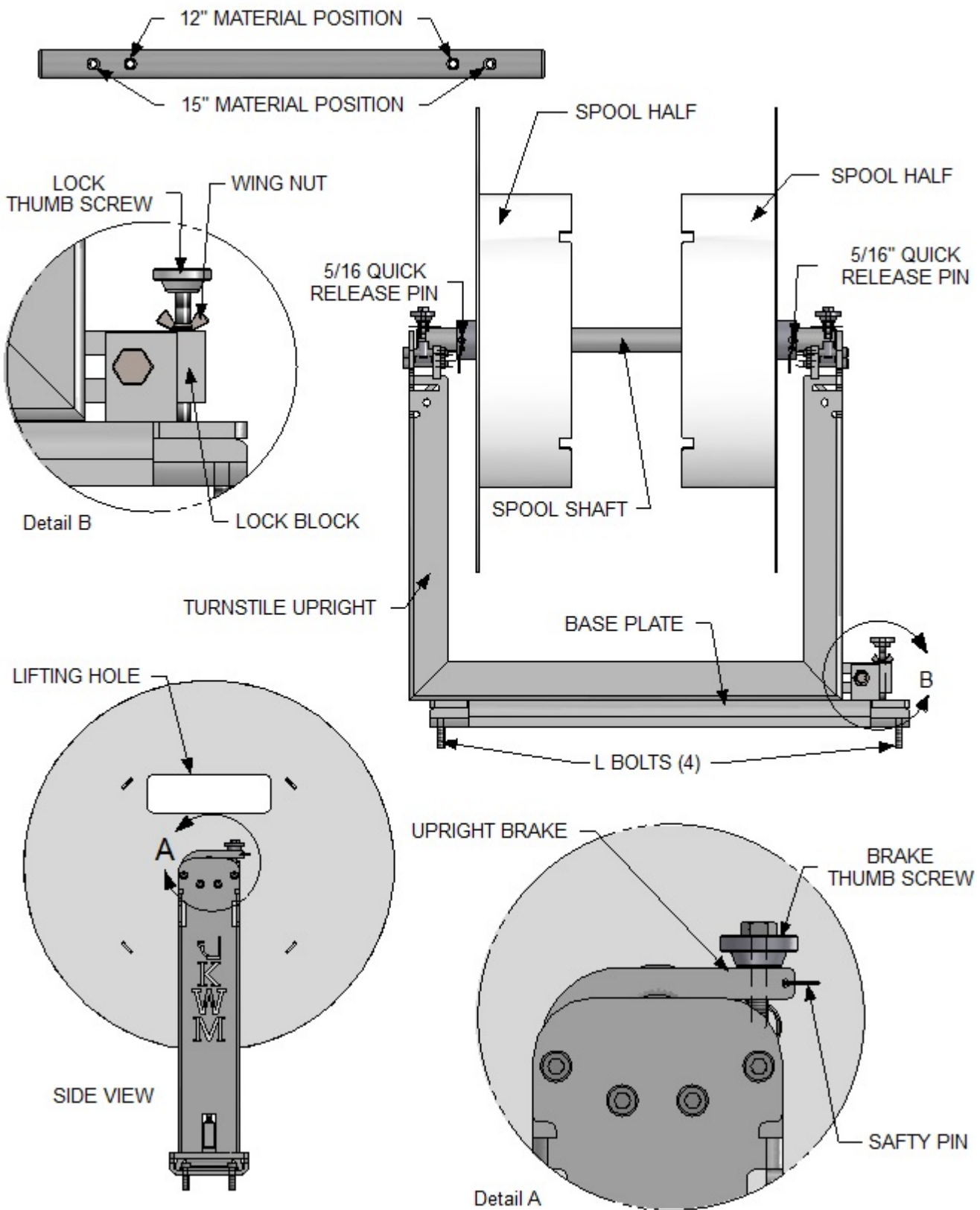

## **SECTION: 9**

### **CRADLE OVERVIEW**

The IRONMAN CRADLE is a modular cradle support used to hold coil. Your machine may have up to three cradles.

**ONE CRADLE ASSEMBLY CONSISTS OF:** (SEE PG. 13)

CRADLE (1)	CRADLE BRAKE (2)
BASE PLATE (1)	CRADLE BRAKE THUMB SCREW (1)
CRADLE LOCKING BOLT (1)	SAFETY PIN (4)
HOLD DOWN SHAFT (1)	

**TO ROTATE TURNSTILE FOR TWO-SIDED COIL:**

1. Loosen LOCKING BOLT.
2. Rotate CRADLE 180 degrees.
3. Tighten LOCKING BOLT.

## **SECTION: 10**

### **CRADLE ASSEMBLY AND LOADING COIL**

**ONE SPOOL ASSEMBLY CONSISTS OF:** (SEE PG. 13)

CRADLE SIDE SHAFT (1)                      5/16" QUICK RELEASE PIN (2)

**TO LOAD COIL ONTO SPOOL ASSEMBLY:**

1. Remove 5/16" quick release pins.
2. Move side shafts into chosen material position.
3. Insert 5/16" quick release pins.
4. Remove Safety Bar
5. Using an appropriate lifting device (jib crane, forklift, anything rated for coil weight that can safely lift coil) place material coil into cradle
6. Install Safety Bar into center of coil

**NOTE:** The cradle assembly is adjustable to accept both 5" gutter material (12") and 6" gutter material (15").

**PLACING COIL IN THE CRADLE:**

Use an approved lifting device in the designated coil lifting area to position the coil into the turnstile upright.

***(IMPORTANT! – Please read PRECAUTIONS)***

**PRECAUTIONS:**

- Make sure loading area is clean and clear of debris.
- Make sure Cradle Locking Bolt is securely installed.
- Always wear protective footwear when handling coil.
- Never operate machine without first checking brake & pin positions.
- Never transport machine without locking brake in closed position.
- Never transport machine without safety bar installed

# CRADLE ASSEMBLY

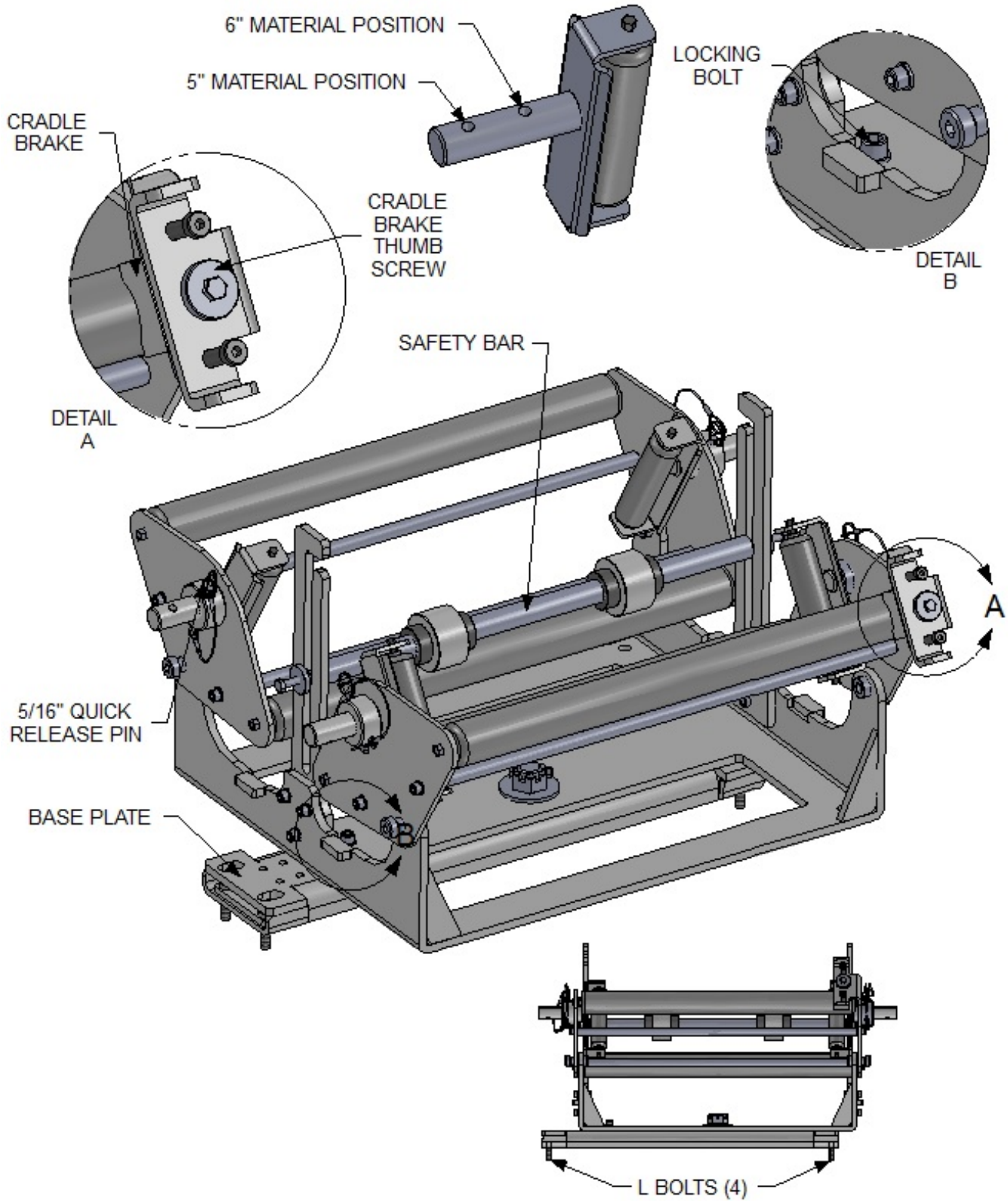

**WARNING:**  
NEVER TRANSPORT COIL IN CRADLE WITHOUT CRADLE BRAKE LOCKED  
DOWN AND SAFETY BAR INSTALLED IN CENTER OF COIL

# **SECTION: 11**

## **ENTRANCE GUIDE SYSTEM**

### **PURPOSE AND PRECAUTIONS OF THE ENTRANCE GUIDE SYSTEM:**

The ENTRANCE GUIDE system is a very important part of this machine. Not only is it used to position material being fed into the machine, but it also controls the lateral relationship of the material to the forming stations.

#### **ENTRANCE GUIDE CONSISTS OF: (SEE PG. 15)**

- A. RIGHT ENTRANCE GUIDE SHOE
- B. LEFT ENTRANCE GUIDE SHOE
- C. RIGHT LOCKING BOLT
- D. LEFT LOCKING BOLT

### **ENTRANCE GUIDE ASSESSMENT:**

- ❖ The RIGHT ENTRY GUIDE (A) controls the amount of material that is fed into the face box and lip box roller assemblies. It should be moved ONLY to increase or decrease the amount of lip turned under.
- ❖ If an adjustment is made on the RIGHT ENTRY GUIDE (A), an adjustment must be made on the LEFT ENTRY GUIDE (B) using coil as a guide. There should be no visible play between the entry guides and the coil. The guide should not be so tight that it would cause the gutter to bind in the entry guide assembly.
- ❖ Before moving the RIGHT ENTRY GUIDE (A), always take a measurement from the inside edge of the entry guide (where the coil will ride) to the inside edge of the frame. This will give a reference point to measure and move from. You can easily return to your original location if you move the guide in the wrong direction.

### **TO MOVE THE GUIDES:**

1. Loosen the bolt on the locking collars (C or D).
2. Move guide
  - A. **To INCREASE the amount of lip turned under,**  
Move the guides toward the RIGHT side (FACE side) of the machine.
  - B. **To DECREASE the amount of lip turned under,**  
Move the guides toward the LEFT side (BACK side) of the machine.
3. Retighten the cap screw.

### **ENTRANCE GUIDE OPERATION:**

When feeding material from the spools on the top of the machine or from a remote station, feed the material straight into the entry guides. **DO NOT FORCE.** Continue pushing material into the machine until it stops. The material can now be jogged through the machine. If the first drive roller does not pull the material into the machine, give the material a little push from the entrance end while continuing to jog the material into the machine.

# ENTRANCE GUIDE ASSEMBLY

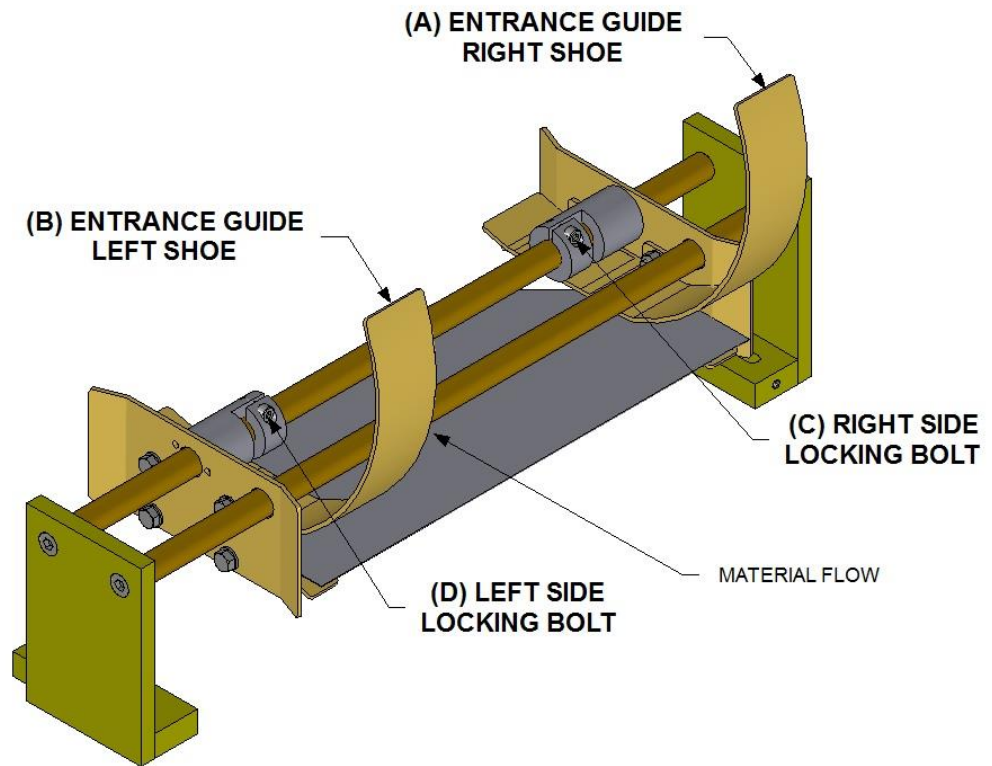

TRIM CORNERS -REMOVING 3" X 3" OF MATERIAL-  
BEFORE FEEDING GUTTER COIL INTO THE MACHINE.

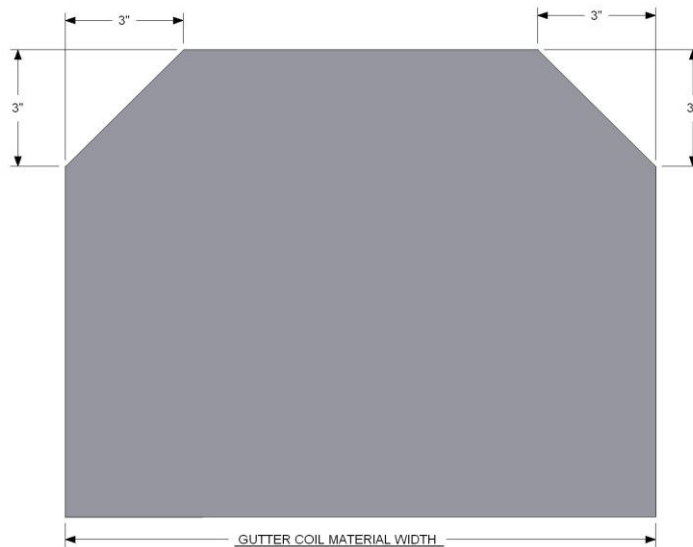

**NOTES:**

---

---

---

# SECTION 12

## CRANK ENTRANCE GUIDE SYSTEM

### 1. Purpose and precautions of the crank entrance guide system.

The entrance guide system is a very important part of this machine. Not only is it used to position material being fed into the machine; it also controls the lateral relationship of the material to the forming stations.

### 2. Crank Entrance guide consists of:

- A. Right Aluminum Guide Roller
- B. Left Aluminum Guide Roller.
- C. Right Locking Set Screw.
- D. Center Locking Set Screw
- E. Left Locking Set Screw.
- F. Top Rubber Drive Roller
- G. Bottom Rubber Drive Roller
- H. Bottom Rubber Drive locking Collars
- I. Plastic Rollers.

### 3. Crank Entry Guide Operation.

When feeding material from the spools on the top of the machine or from a remote station, position the material in the middle of the entry guide top plastic rollers and between the entrance rubber drives. Turn the handle to feed material until it stops at the first chain driven rubber drive. **DO NOT FORCE**. The material can now be jogged through the machine. If the drive roller does not pull the material into the machine, give the material a little push from the entry end while continuing to jog the material into the machine.

### CRANK ENTRANCE GUIDE ASSEMBLY DRAWING

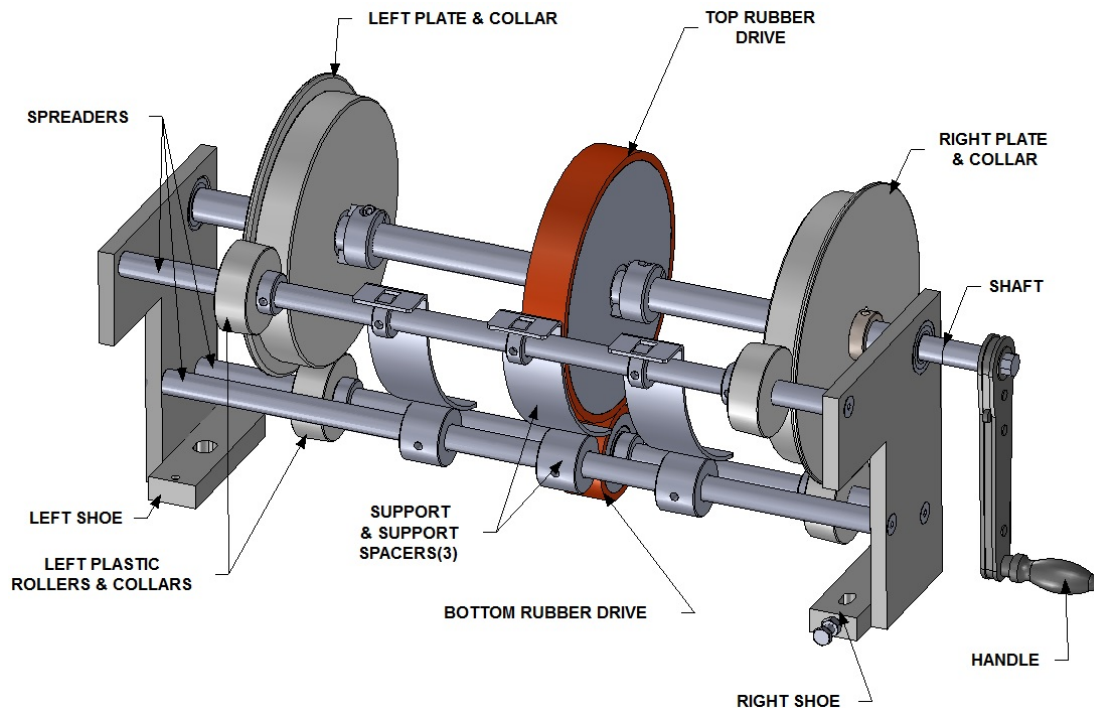

### MATERIAL INSERTED BETWEEN ROLLERS AND GUIDES

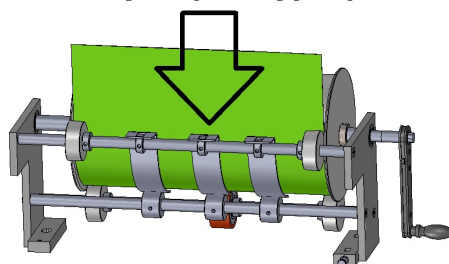



## SECTION: 13

### **POLYURETHANE DRIVE SYSTEM**

The drive train of this machine is in most circumstances maintenance free.

If a material traction problem arises or a roller is replaced, the top roller is adjustable up and down.

#### **CAUTION: DO NOT OVER TIGHTEN DRIVE ROLLERS**

The factory setting for the rollers is 1/4 turn past the point of contact.

The **MAXIMUM** amount of drive pressure recommended is 1/4 turn past factory setting. Do Not ADJUST Station #3.

#### **ADJUSTING DRIVE SYSTEM TO ADD TRACTION:**

Start with top #1 drive assembly; **COMPONENT LOCATIONS: (SEE PG. 6 for 5" & SEE PG. 8 for 6")**

- 1.) Turn locking nuts (C) counter clockwise. Four places.
- 2.) Turn locking bolt (B) counter clockwise a 1/8 a turn to loosen all four bolts.
- 3.) Turn adjustment bolts (A) clockwise 1/8 of a turn to tighten all four bolts
- 4.) Tighten locking nuts (C).

Run machine forward, if more traction is needed repeat the above procedure on top #2 drive assembly.

Run the machine forward; if more traction is needed repeat above procedure on both #1 and #2 drive assemblies.

**NOTE:** If material slippage occurs after material leaves #2 drive assembly while clearing machine, add pressure to #3 drive forming assembly (SEE PG. 24).

#### **RUBBER DRIVE ASSEMBLY**

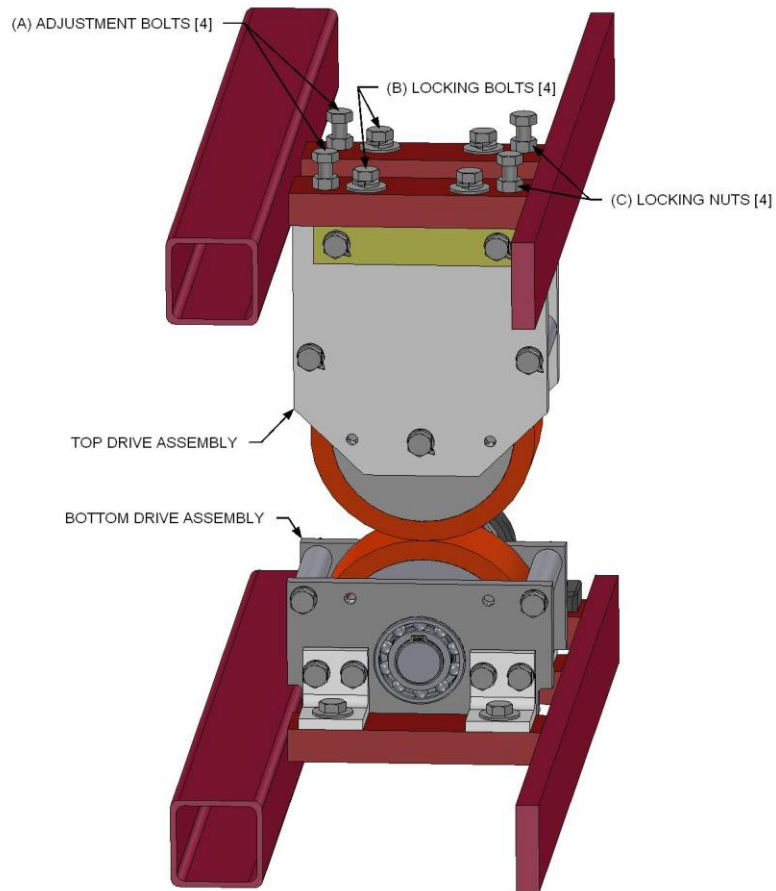

**CLEANING OF POLYURETHANE:** clean outer surface of rollers using Windex or a like kind product to remove any dirt or debris.

# **SECTION: 14**

## **FORMING COMPONENTS AND ASSEMBLIES**

### **GUIDE BAR COMPONENTS:**

- The guide bars are in a fixed position relative to the forming stations.
- The back guide bar must be in contact with the material at all times.
- The face guide bar supports the face portion of material guiding it into the face forming box assembly.
- The back guide bar supports the back portion of material through the complete forming process and bends the back bottom corner of the gutter.
- The guide bars are not adjustable components on standard 5" or 6" machines.

### **GUIDE BAR MAINTENANCE:**

- Check guide bars for marks, burrs, or build up that could cause a mark or scratch on gutter.
- To clean guide bars, lightly sand guide with a fine grit emery cloth & polish out any remaining marks with Scotch Brite.

### **FACE FORMING BOX ASSEMBLY:**

- This assembly consists of two forming planes- four forming rollers per plane. This assembly's sole purpose is to form the face of the gutter; it does not do any driving of material.
- The unique design of this assembly requires no adjustment for alignment of rollers. The spacing of the roller and the position of the assembly are factory set and should not be altered.

### **FORMING ROLLER MAINTENANCE:**

- The forming rollers are hard chrome plated to eliminate corrosion.
- Check rollers for marks, burrs, or build up.
- If a roller becomes marked, use a fine grit emery cloth to remove the mark, then polish out any remaining marks or scratches with Scotch Brite.

# SECTION: 15

## LIP FORMING BOX (FORMS THE LIP PORTION OF THE GUTTER)

The FORMING BOX consists of 7 stations (#1 = ENTRANCE & #7 = EXIT) and three color-coded adjustment areas.

### COLOR-CODED ADJUSTMENTS:

- **BLUE:** Swing Shaft Assembly
- **BLACK:** Entrance Box Mount
- **GREEN:** Exit Box Mount

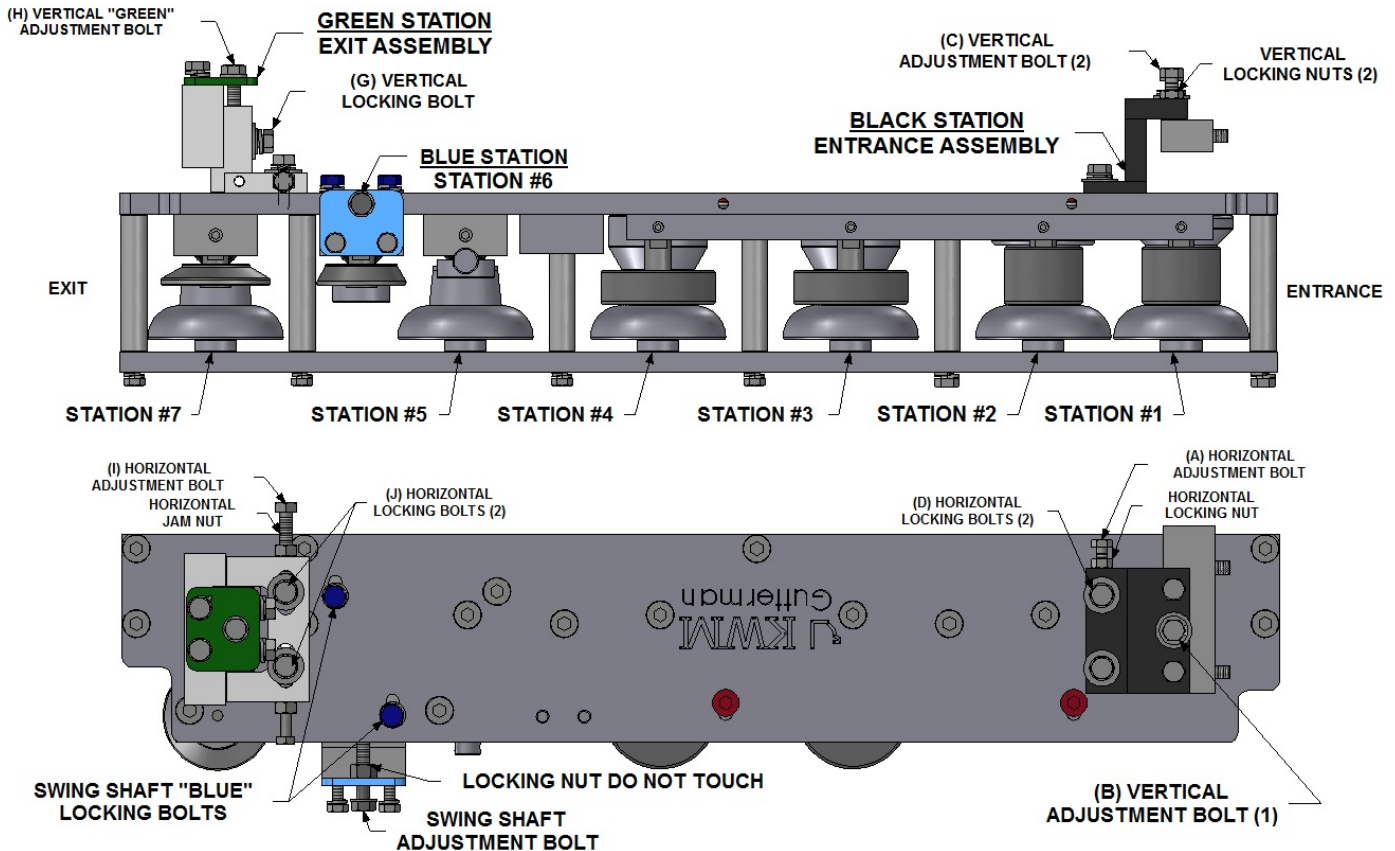

**ROLLER MAINTENANCE:** The forming rollers in this assembly are made from stainless steel. Maintenance is the same procedure as the face forming rollers (SEE PG. 19).

### SWING SHAFT ASSEMBLY (BLUE STATION):

The primary purpose of the SWING SHAFT or BLUE STATION is to control the top lip of the gutter.

- ❖ Adding pressure to this assembly will cause the top lip of the gutter to run into the fascia.
- ❖ Relieving pressure will cause the top lip of the gutter to run away from the fascia.

### ADJUSTING SWING SHAFT ASSEMBLY:

1. Loosen swing shaft locking bolt (2 places) to allow swing shaft assembly to slide.
  - a. **TO ADD PRESSURE**, turn swing shaft adjustment bolt clockwise.
  - b. **TO RELIEVE PRESSURE**, turn swing shaft adjustment bolt counter-clockwise.

**PRECAUTION:** Do not over adjust this assembly. Moving the swing shaft past its range will cause the opposite affect to the gutter. The forming box is a critical part of this machine. When adjusting in this area, move adjustments incrementally 1/8 of a turn at a time. Always return to original position before trying a different adjustment.

### ENTRANCE LIP BOX MOUNT LOCATION:

- The ENTRANCE BOX MOUNT has primary purpose in aligning the entrance of the forming box with the exit of the face-forming box.
- Looking through the guillotine, see that the lateral alignments between the forming rollers of both boxes are in line. ***THIS LOCATION IS FACTORY SET & SHOULD NOT BE ALTERED.***
- The vertical (height) adjustment is used to line up the inside radius of the box rollers with the last (top) bend coming out of face rollers. (1 3/8" ON 5" GUTTER: and 1 5/8" ON 6" GUTTER)

#### A. TO RAISE THE STATION:

1. Loosen the two LOCKING NUTS (C) on adjustment bolts (B).
2. Turn LOCKING BOLT (A) counter-clockwise.
3. Equally turn the two ADJUSTMENT BOLTS (B) clockwise to the desired height.
4. Tighten LOCKING BOLT (A) and LOCKING NUTS (C).

#### B. TO LOWER THE STATION:

1. Loosen the two LOCKING NUTS (C) on adjustment bolts (B).
2. Equally turn the two ADJUSTMENT BOLTS (B) counter-clockwise to the desired height.
3. Tighten LOCKING BOLT (A) and LOCKING NUTS (C) in 2 places.

C. Run metal completely through machine, back metal up 6" to 10", check for double track prior to the lip box.

D. If necessary, repeat to raise or lower.

## ENTRANCE LIPBOX MOUNT

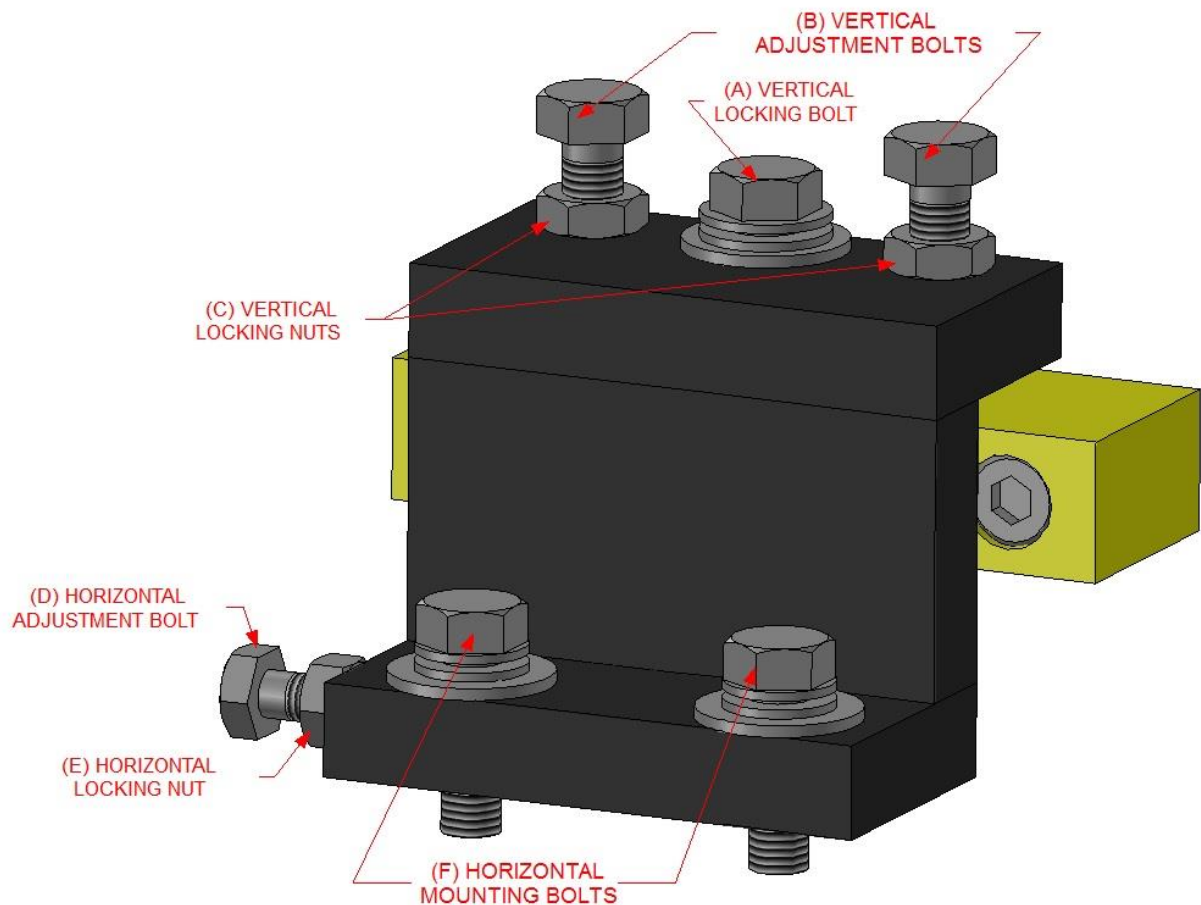

**PRECAUTION:** The forming box is a critical part of this machine. When adjusting in this area, move adjustments incrementally 1/8 of a turn at a time. Always return to original position before trying a different adjustment.

## EXIT LIP BOX MOUNT LOCATION

- The VERTICAL exit box mount adjustment is used to control the up and down hill on the face-side of the bottom.
- The LATERAL adjustment is used to control the width across the opening of the gutter.

### A. VERTICAL ADJUSTMENT:

1. To adjust the exit end of the box up or down, first loosen LOCKING BOLTS G (2).
  - a. **TO RAISE THE BOX:**
    - i. Turn ADJUSTMENT BOLT J clockwise.
  - b. **TO LOWER THE EXIT END OF THE BOX:**
    - i. Turn ADJUSTMENT BOLT J counter-clockwise.
2. When desired height is reached, tighten LOCKING BOLTS G (2).

### B. LATERAL ADJUSTMENT:

1. To adjust the exit end of the lip box in or out, first loosen LOCKING NUT (L) and MOUNTING BOLTS K (2 places).
  - a. **TO MOVE TOWARDS THE BACK OF THE GUTTER:**
    - i. Loosen LOCKING NUT (L) and tighten ADJUSTMENT BOLT (M).
  - b. **TO MOVE AWAY FROM THE BACK OF THE GUTTER:**
    - i. Loosen LOCKING NUT (L) and ADJUSTMENT BOLT (M).
    - ii. Clear any material from the lipbox, pull on the lipbox until the HORIZONTAL MOUNTING BOLT (K) hits the HORIZONTAL ADJUSTMENT BOLT (M)
2. After completing adjustment, tighten LOCKING NUT (L) and MOUNTING BOLTS K (2 places).

## EXIT LIPBOX MOUNT

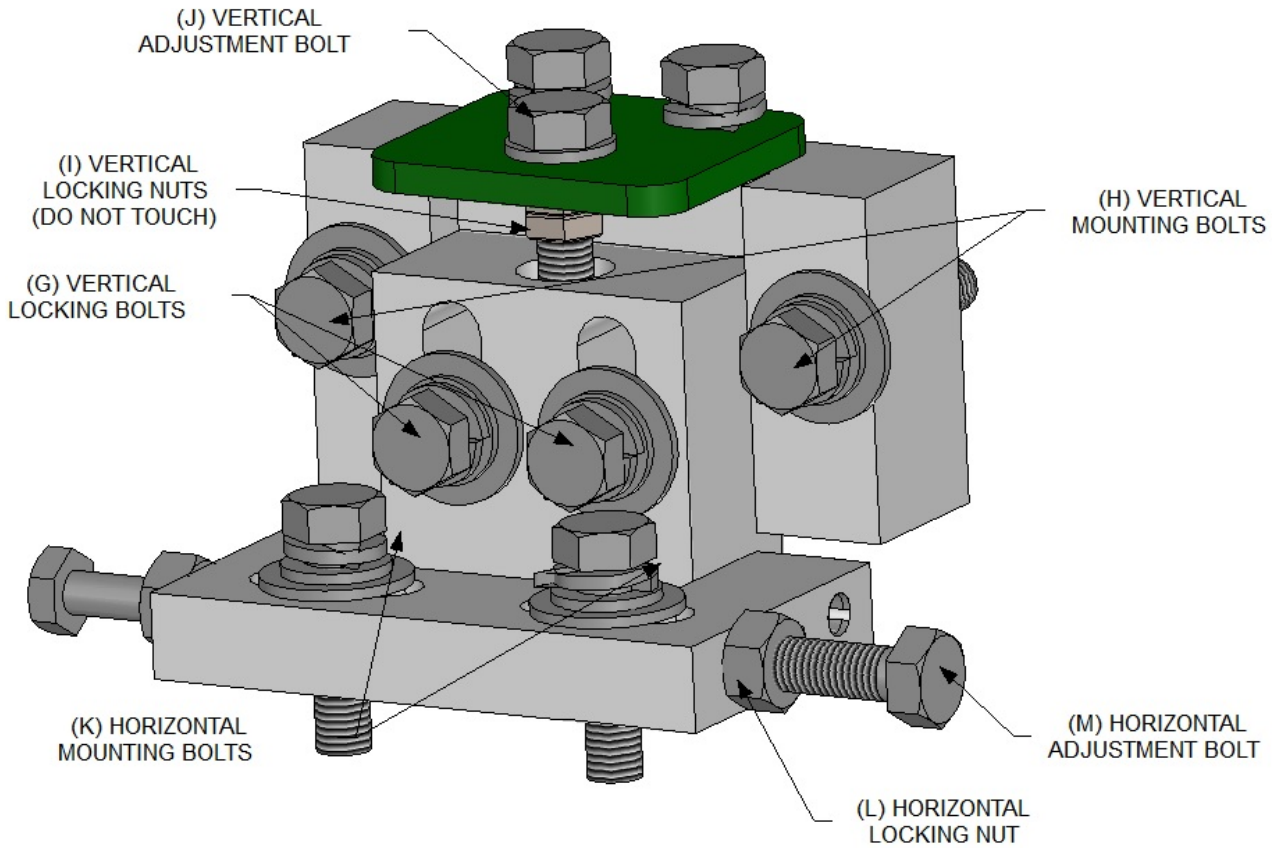

## SECTION: 16 EXIT END FORMING AND DRIVE ASSEMBLY

This assembly is a very important part of the machine. Not only does it finish the forming process, but it also drives the material out of the machine.

### IRONMAN EXIT DRIVE ASSEMBLY SET UP DIMENSIONS

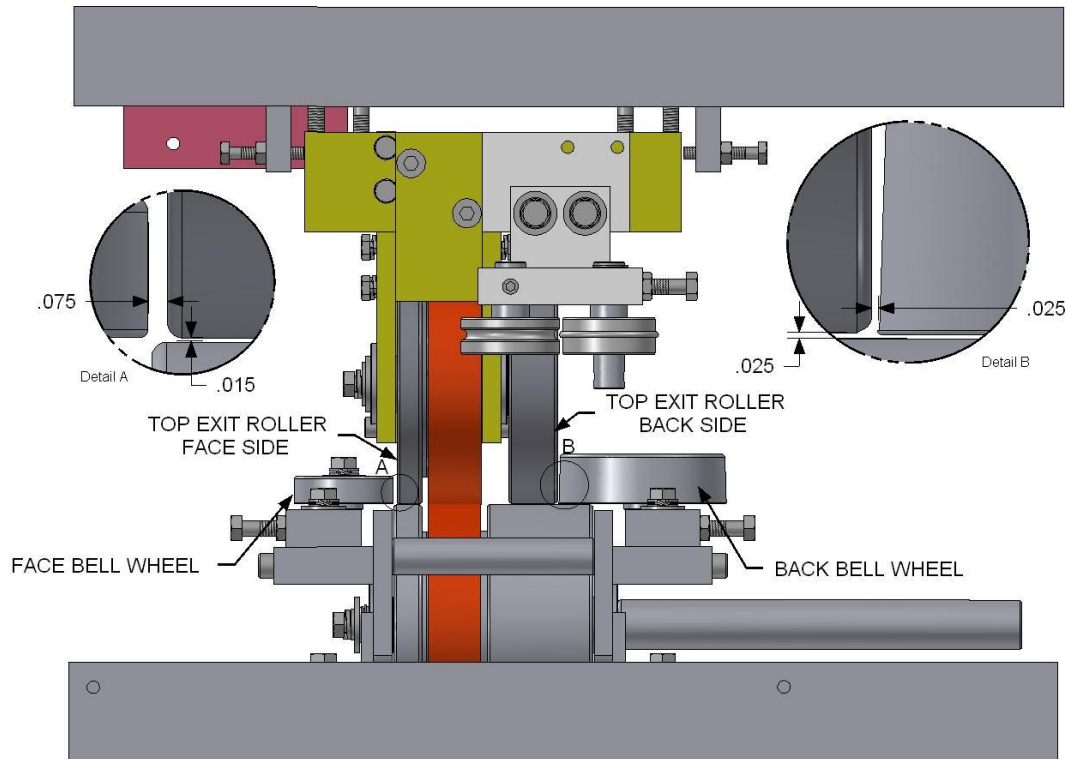

#### **IMPORTANT:**

- The #3 SKATE and the EXIT END FORMING DRIVE STATION are bolted together by BOLTS (K) to ensure that the drive roller stays square to the skate.
- Before making any adjustment to this assembly, you must loosen BOLTS K (2 places).

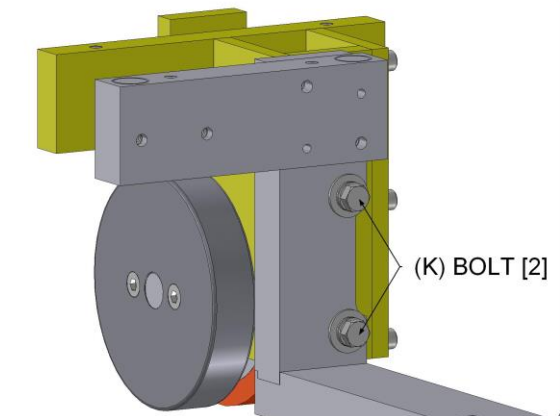

**CAUTION:** Always make sure BOLTS K is retightened after adjustment.

## IRONMAN TOP EXIT DRIVE ADJUSTMENT

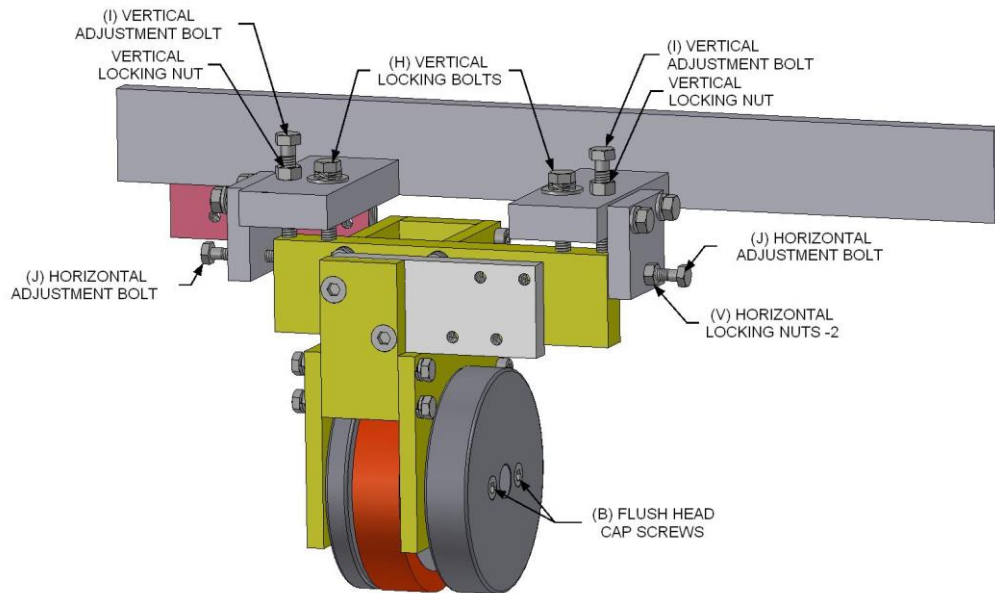

### 1. FACE-SIDE OF TOP EXIT ROLLER ASSEMBLY:

- This area will control into the house and also up & downhill on the face-side bottom of the gutter.
- This station is very responsive; make small incremental adjustments of less than 1/32 of a turn.

#### ADJUSTMENT:

1. Loosen HORIZONTAL LOCKNUT (V) on HORIZONTAL ADJUSTMENT BOLT (J).
2. Loosen VERTICAL LOCKING BOLT (H) and the LOCK NUT on VERTICAL ADJUSTMENT BOLT (I).
3. **TO ADD PRESSURE**; turn ADJUSTMENT BOLT (I) clockwise.
  - a. **TO RELIEVE PRESSURE**, turn ADJUSTMENT BOLT (I) counter-clockwise.
4. Tighten LOCKING BOLTS and NUTS

### 2. BACK SIDE OF TOP EXIT ROLLER:

#### ADJUSTMENT:

1. Loosen HORIZONTAL LOCKNUT (V) on HORIZONTAL ADJUSTMENT BOLT (J).
2. Loosen VERTICAL LOCKING BOLT (H) and the LOCK NUT on VERTICAL ADJUSTMENT BOLT (I).
3. **TO ADD PRESSURE**; turn ADJUSTMENT BOLT (I) clockwise.
  - a. **TO RELIEVE PRESSURE**, turn ADJUSTMENT BOLT (I) counter-clockwise.
4. Tighten LOCKING BOLTS and NUTS

### 3. ADDING PRESSURE TO EXIT POLYURETHANE DRIVE ROLLER:

- The top exit roller is very responsive to adjustment; make all adjustments in very small increments.
- DO NOT exceed 1/32 of a turn past factory setting.

#### ADJUSTMENT:

1. Loosen LOCKNUTS on ADJUSTMENT BOLTS (J), (H), and (I).
2. Loosen LOCKING BOLTS (J) 1/16 of a turn counter-clockwise.
3. **TO ADD PRESSURE**,
  - a. Turn ADJUSTMENT BOLTS (I) equally a 1/64 of a turn clockwise.  
*Make sure to add pressure equally to both sides.*
4. Tighten LOCKING BOLTS and NUTS

#### 4. FACE BELL ROLLER AND BACK BELL ROLLER:

- Adjusting bell rollers will control the squaring of the bottom corners of the gutter as well as into and away from the house.

#### ADJUSTMENT

1. Loosen PIVOT BOLT, LOCKING BOLT, and the LOCKNUT on ADJUSTMENT BOLT.
2. **TO MOVE BELL ROLLER CLOSER TO THE TOP DRIVE ASSEMBLY:**  
Turn ADJUSTMENT BOLT counter-clockwise (this will allow bell wheel to move towards top roller).
3. **TO MOVE BELL ROLLER AWAY FROM THE TOP DRIVE ASSEMBLY:**  
Turn ADJUSTMENT BOLT clockwise to the desired clearance.
4. Tighten PIVOT BOLT, LOCKING BOLT, and LOCKNUT on ADJUSTMENT BOLT.

## BELL WHEEL ASSEMBLIES

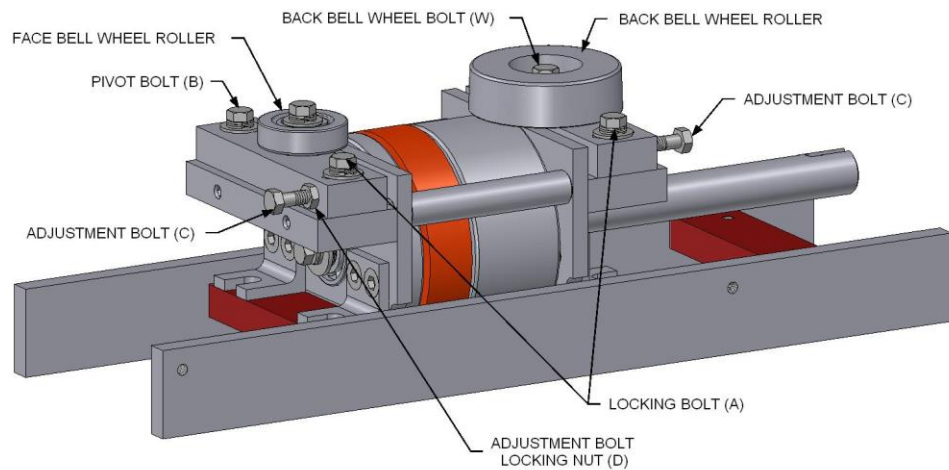

## SECTION: 17

### BEAD ROLLER ASSEMBLY

The BEAD ROLLER is used to give the back section of the gutter some form and structure. The amount of pressure will also control up & downhill on the back of the gutter.

**FACTORY SETTING:** VERTICAL height of bead roller is 1/4" down from the top of the back of the gutter;  
HORIZONTAL position is a 1/32" gap between the material being formed and the back-side of the top exit roller.

### BEAD ROLLER ASSEMBLY

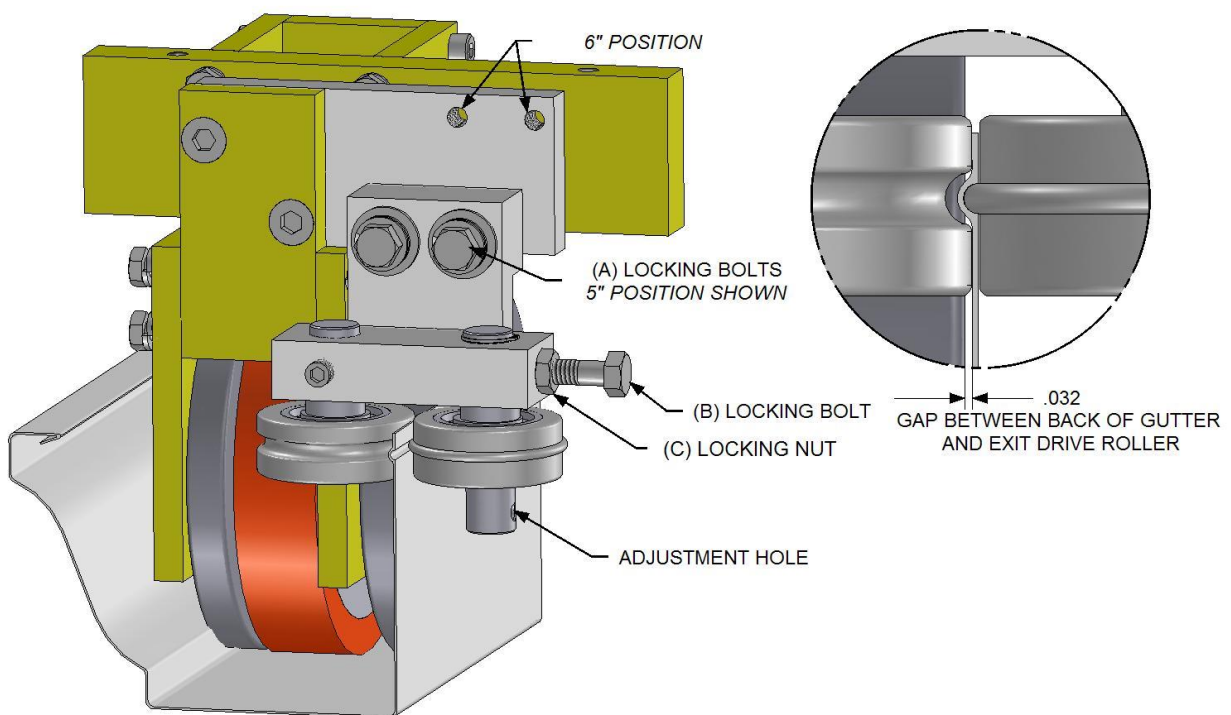

#### 1. BEAD ROLLER ADJUSTMENT:

- a. Loosen BOLTS A (2 places) to align bead roller assembly, and retighten after alignment is made.
- b. **TO INCREASE OR DECREASE PRESSURE** to bead itself, loosen LOCKING NUT C and LOCKING BOLT B, and turn eccentric shaft using a 3/16 Allen wrench in the adjustment hole to desired spacing.
- c. Adding too much pressure to the bead will cause the back of the gutter to run uphill. If this happens, simply relieve pressure from bead and retighten LOCKING BOLT and LOCKING NUT.

## **SECTION: 18**

### **GUILLOTINE AND FACE PLATE ASSEMBLY**

- The guillotine assembly is machined to very tight tolerance, requiring that it be maintained on a regular basis.
- If the guillotine assembly is kept clean, lubricated and all hardware tight, you can expect trouble free performance for years to come.

❖ **DAILY MAINTENANCE:**

Lubricate GUILLOTINE blade using 20 or 30-weight oil or WD 40 DAILY.

❖ **ADJUSTING GUILLOTINE POSITION.** (See pg. 28)

The guillotine is moveable in all directions.

To Raise Guillotine

1. Loosen locking bolts (C) - 6 places
2. Loosen locking nuts (A) on adjustment bolts (B) - 2 places
3. Turn adjustment bolts (B) - 2 places clockwise tap guillotine down.
4. After desired position is acquired, tighten locking bolts (C) 6 places
5. Tighten locking nuts (A) on adjustment bolts (B) 2 places.

To Lower Guillotine

1. Loosen locking bolts (C) - 6 places
2. Loosen locking nuts (A) on adjustment bolts (B) - 2 places
3. Turn adjustment bolts (B) - 2 places counter clockwise
4. After desired position is acquired, tighten locking bolts (C) 6 places
5. Tighten locking nuts (A) on adjustment bolts (B) 2 places.

To move guillotine side to side

1. Loosen locking bolts (D) – 4 places. (GUILLOTINE is now free to move in all directions.)
2. After desired position is acquired, tighten locking bolts (D) – 4 places

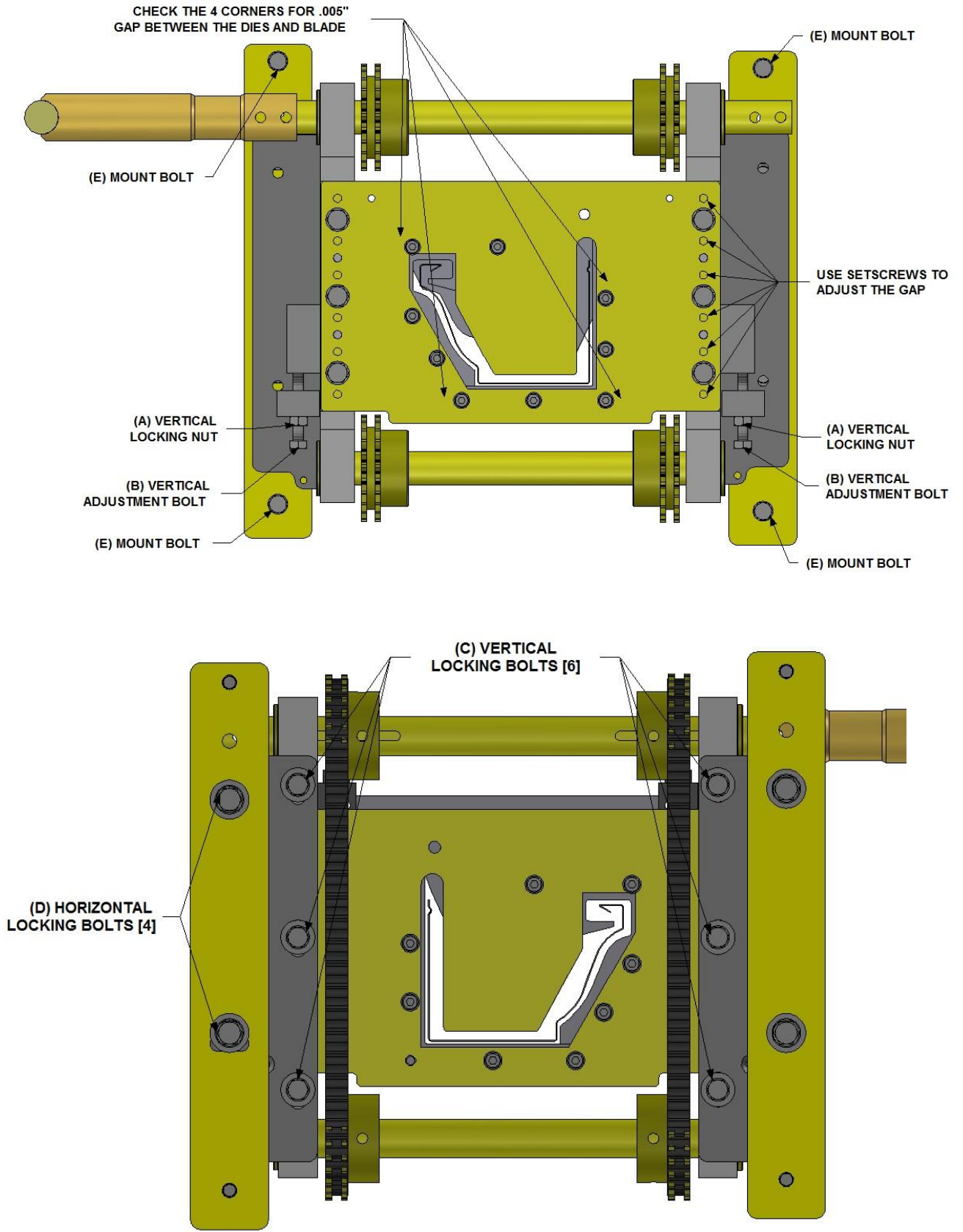

# SECTION 19

## **BASIC MACHINE SETUP AND DIMENSIONS**

- The factory starting position for all components are in relation to a reference line.  
(A 30-weight fishing line strung between two 5/16" – 18 x 2" set screws).
- The line must be secured to the inside of the setscrews approximately 5/16" off of the inside wall of the machine frame on the face-side 2 inches up from the bottom (SEE PG. 30).

### 1) **ENTRY GUIDES**

- a. This dimension labeled as (1) on PG. 30 is measured from the inside edge of the entrance guide.  
(Where the coil will ride to the inside edge of the frame.)
- b. Set the right shoe first, and then bring the left shoe to the right  
(Snug enough to support material without binding).
  - i. **(1) RIGHT ENTRANCE GUIDE DIMENSIONS**  
5" IRONMAN: 1 1/2"  
6" IRONMAN: 5/16"

### 2) **LIP FORMING BOX HORIZONTAL ENTRANCE PLACEMENT**

### 3) **LIP FORMING BOX HORIZONTAL EXIT PLACEMENT**

- a. These dimension labeled as (2) and (3) on PG. 30 is the horizontal position of the lip-forming box.
- b. This measurement is from the outside of skate vertical posts to the inner edge of the bottom box plate.
  - i. **(2) LIP BOX ENTRANCE DIMENSIONS**  
5" IRONMAN: 5-3/8"  
6" IRONMAN: 5-13/16"
  - ii. **(3) LIP BOX EXIT DIMENSIONS**  
5" IRONMAN: 5"  
6" IRONMAN: 5-7/16"

### 4) **SWING SHAFT ASSEMBLY BOX STATION #6 (BLUE STATION)**

- a. The dimension labeled as (4) on PG. 30 is the position of the inside edge of the blue half inch adjustment block station #6 to the outside edge of the box top plate.
  - i. **(4) SWING SHAFT DIMENSIONS**  
5" IRONMAN: 11/16"  
6" IRONMAN: 11/16"

### 5) **LIP FORMING BOX VERTICAL ENTRANCE PLACEMENT**

### 6) **LIP FORMING BOX VERTICAL EXIT PLACEMENT**

- a. The dimension labeled as (5) and (6) on PG. 30 is the vertical position of the lip-forming box.
- b. This measurement is from the top of the skate rail to the top edge of the box.
  - i. **(5) LIP BOX ENTRANCE VERTICAL DIMENSIONS**  
5" IRONMAN: 3-9/16"  
6" IRONMAN: 4-5/8"
  - ii. **(6) LIP BOX EXIT VERTICAL DIMENSIONS**  
5" IRONMAN: 3-3/4"  
6" IRONMAN: 4-7/8"

- **TOP #3 EXIT DRIVE FORMING ROLLER:** (SEE DRAWING on PG. 23)
- **ENTRY SKATE #1 SKATE:**  
Dimensions on PG. 30 are from top of the bottom frame rail to bottom of the skate bearings.
- **BOTTOM KEEL RAILS:**  
Dimensions on PG. 30 for the bottom keel rails are from the edge of the keel to the string, as illustrated on PG. 30.
- **TOP SKATES:** The top skates are positioned 1/16" inside of bottom rollers on the face-side, as illustrated on PG. 30.

## BASIC MACHINE SETUP DRAWING

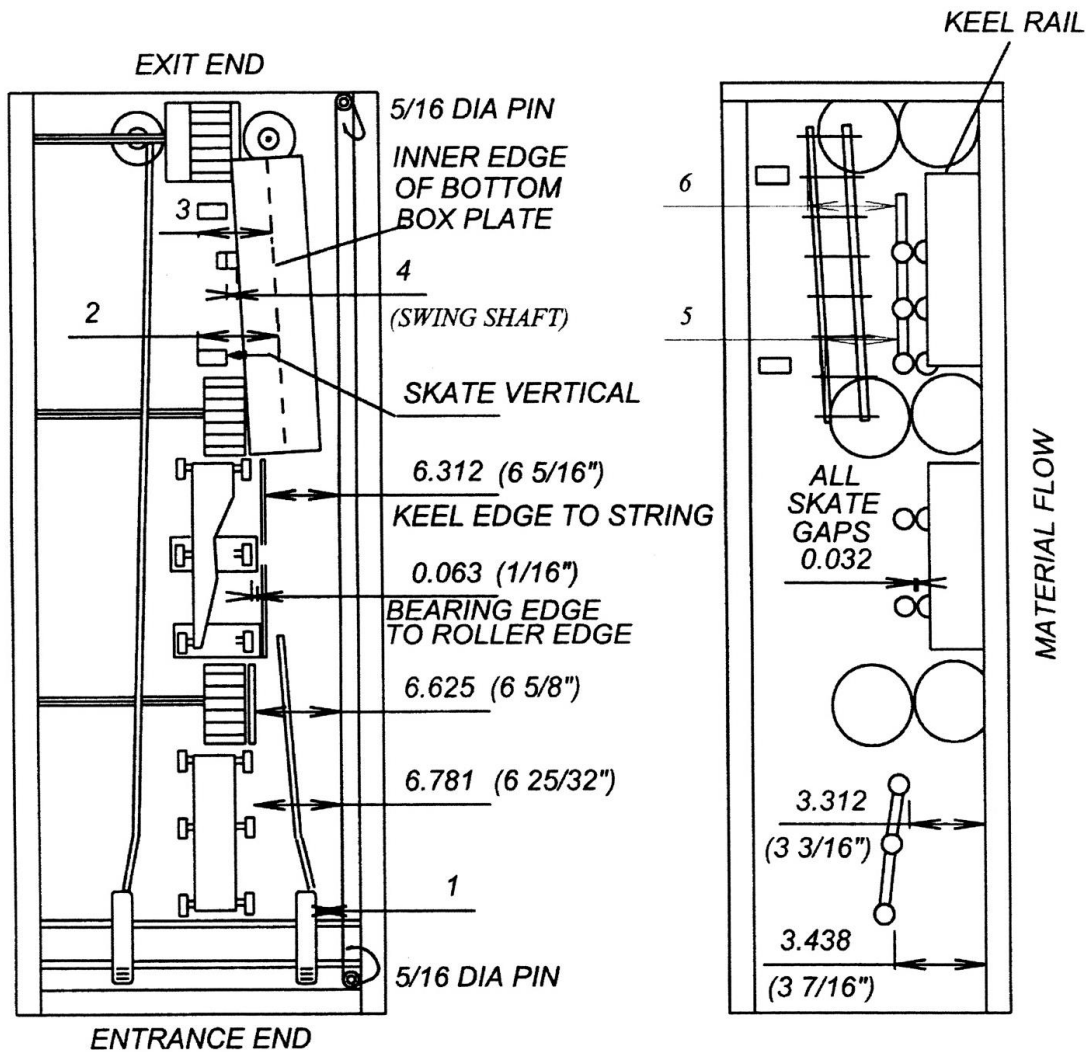

P34I.CAD	1	2	3	4	5	6
STANDARD 5" GUTTER	1 1/2"	5 3/8"	5"	11/16"	3 9/16"	3 3/4"
STANDARD 6" GUTTER	5/16"	5 13/16"	5 7/16"	11/16"	4 5/8"	4 7/8"
STANDARD 5" GUTTER	1 1/2"	5 3/8"	5"	11/16"	3 9/16"	3 3/4"
STANDARD 6" GUTTER	5/16"	5 13/16"	5 7/16"	11/16"	4 5/8"	4 7/8"

## SECTION: 20

### GUTTER TALK

Common terms describing the condition of the gutter:

#### RUNNING UPHILL

This term describes a condition where the ends of the gutter are higher along the fascia board than the center.



GUTTER RUNNING UPHILL



GUTTER RUNNING DOWNHILL

#### RUNNING DOWNHILL

This term describes a condition where the ends of the gutter are higher along the fascia board than the center.



GUTTER RUNNING INTO THE HOUSE

#### INTO THE HOUSE

This term describes a condition where the ends of the gutter are closer to the fascia board than the center. Looking from the machine the gutter has a left hand curve.



GUTTER RUNNING AWAY FROM THE HOUSE

#### AWAY FROM THE HOUSE

This term describes a condition where the center of the gutter is closer to the fascia board than the ends. Looking from the machine the gutter has a right hand curve.



GUTTER LIP RUNNING INTO THE HOUSE

#### TOP LIP INTO THE HOUSE

This term describes a condition where the end of the top lip is closer to the fascia board than the middle.

#### TOP LIP AWAY FROM THE HOUSE

This term describes a condition where the end of the top lip is further away from the fascia than the middle.



GUTTER LIP RUNNING AWAY FROM THE HOUSE

## **SECTION: 21**

### **MACHINE OPERATION RECAP AND SUMMARY**

This section is only a brief summary. Please read the entire manual prior to operation.

#### **ORDER OF OPERATION:**

1. Connect the machine to the proper power source using the proper extension cord.
2. Position the selector switches to the JOG position and the FORWARD position.
3. Loosen thumbnuts, removing pressure on the spool brakes from the spool that you have selected to run.
4. Trim both corners of the coil at a 45-degree angle approximately 3" in from edges. Insert trimmed coil into the entrance guide system, making sure that coil is snug to both sides with free front to back movement.
5. Push coil to #1 drive station.
6. With the material positioned in the entrance guides, grasp the material with one hand, reach around to the right side of the machine, and press the JOG button while pushing the material until it engages the #1 drive assembly. With the material moving forward under its own power, release JOG button.
7. Using the green start button at the main operator's panel, advance the material through the guillotine approximately 12", and then cut off the 12" section of gutter.
8. The selector switches can be used for FORWARD/REVERSE and JOG/RUN operation of the machine once machine is fed. Set the selector switch to run mode. By depressing START button, machine will run continuously. Depress red button to stop machine.
9. Jog gutter to desired length and cut off using guillotine. Run out support stands must be used to support gutter after 8'.
10. Prior to the completion of the last piece of gutter being produced, cut the coil stock before the entrance guides to clear machine. **The IRONMAN MACHINE should be empty when transporting from job to job.**

## **SECTION: 22**

### **ANALYZING GUTTER**

**STEP #1:** Feed the machine with the material (through entire machine).

**STEP #2:** Run gutter through the guillotine approximately 12".

**STEP #3:** Back gutter up 3".

**STEP #4:** Visually check POINTS for double track. (SEE PG. 36)

- A double track is a misalignment of stations; with the gutter backed up, it will show as two lines or a double line.
- A double track located on POINTS 6 & 7 are formed by the skate assemblies.
- A double track on POINT 4 is controlled by the vertical adjustment of the entrance end of the lip box.

**STEP #5:** Measure the amount of material entering the forming box.

- This measurement is taken between the face rollers and the lip box.
- FOR 5" gutter there should be 1 3/8" of material, and FOR 6" gutter there should be 1 5/8" (SEE PG. 35).

**STEP #6:** Measure top width of the gutter from POINT 3 to POINT 9. (SEE PG. 36)

- Correct measurement: 5" width for 5" gutter and 6" width for 6" gutter (+/- 1/8").
- The width of the top of the gutter is controlled by the exit end of the box, GREEN station, and the bell rollers
- Prior to measuring the top of the gutter, make sure that the back of the gutter is square to the bottom at POINT 7.

**STEP #7:** Check POINT 5 for being square to the bottom. (SEE PG. 36)

**STEP #8:** With no double tracks, proper amount of metal in forming box, and the correct width across the top of the gutter, you are now ready to make some corrective adjustments to the machine.

# **SECTION: 23**

## **TROUBLE SHOOTING**

### **1. ADJUSTING THE TOP LIP OF GUTTER**

The two conditions listed below will be corrected using the **SWING SHAFT (BLUE station)**.  
(SEE SWING SHAFT ASSEMBLY PG. 20)

- a. Top lip lines #3 & #4 are running **DOWN** and **AWAY** from the fascia. (SEE PG. 36)  
The bottom lines #6 & #7 are **STRAIGHT** and **PARALLEL** to the fascia board and are satisfactory.
- b. Top lip lines #3 & #4 are running **UP** and **INTO** the fascia. (SEE PG. 36)  
The bottom lines #6 & #7 are **STRAIGHT** and **PARALLEL** to the fascia board and are satisfactory.

**\*\* CAUTION: Over-adjustment will cause *OPPOSITE* reaction. \*\***

- A.) To correct for **DOWN and AWAY** from fascia: Add pressure to the SWING SHAFT.
  - i. Turn LOCKING BOLT E counter-clockwise to loosen (2 places).
  - ii. Turn ADJUSTMENT BOLT F clockwise to tighten 1/16 of a turn per adjustment.
  - iii. Re-tighten LOCKING BOLT E (2 places) (SEE PG. 21).
- B.) To correct for **UP and INTO** the fascia: Relieve pressure from the SWING SHAFT.
  - i. Turn LOCKING BOLT E counter-clockwise to loosen (2 places).
  - ii. Turn ADJUSTMENT BOLT F counter-clockwise to loosen 1/16 of a turn per adjustment.
  - iii. Retighten LOCKING BOLT E (SEE PG.21).

➤ **NOTE:** After adjustment is made, run an 8' section of gutter to inspect it. If more adjustment is needed, repeat procedure.

➤ **NOTE:** Adjusting SWING SHAFT will not increase or decrease the amount of lip.

➤ **NOTE:** The SWING SHAFT should not be used to try and change the size of the hanger lip.

### **2. ADJUSTING THE BOTTOM PORTION OF GUTTER**

The two conditions listed below will be corrected using the **EXIT-END BOX MOUNT (GREEN station)**.  
(SEE EXIT BOX MOUNT ASSEMBLY PG. 22)

- a. The whole gutter is running **DOWN and AWAY** from the fascia board. (SEE PG. 31)  
The top lip lines #3 & #4 are **PARALLEL** to lines #6 & #7 of the bottom. (SEE PG. 33)
- b. The whole gutter is running **UP and INTO** the fascia board. (SEE PG. 31).  
The top lip lines #3 & #4 are **PARALLEL** to lines #6 & #7 of the bottom. (SEE PG. 36)

**\*\* CAUTION: Over-adjustment will cause *OPPOSITE* reaction. \*\***

- A.) To correct for **DOWN and AWAY** from the fascia board: Move exit mount of the box downward.
  - i. Turn LOCKING BOLT G counter-clockwise to loosen.
  - ii. Turn ADJUSTMENT BOLT J counter-clockwise 1/16 of a turn per adjustment.
  - iii. Retighten LOCKING BOLT G.
- B.) To correct for **UP & INTO** the fascia board: Move exit mount of the box upward.
  - i. Turn LOCKING BOLT G counter-clockwise to loosen.
  - ii. Turn ADJUSTMENT BOLT J clockwise 1/16 of a turn per adjustment.
  - iii. Retighten LOCKING BOLT G.

- ❖ Use #3 DRIVE FORMING ROLLER and SWING SHAFT ASSEMBLY as a secondary option to acquire the same results. (SEE PG. 23 & 24)

➤ **NOTE:** Loosen LOCKING BOLT K prior to adjusting the top #3 DRIVE FORMING ASSEMBLY.

**\*\* CAUTION: Over-adjustment will cause OPPOSITE reaction. \*\***

- A.) **To correct for DOWN and AWAY from the fascia board:**  
Add pressure to the face side of the top #3 DRIVE FORMING ROLLER.
  - i. Turn locknut on ADJUSTMENT BOLT I counter-clockwise to loosen.
  - ii. Turn ADJUSTMENT BOLT I clockwise 1/64 of a turn.
  - iii. Add pressure to the SWING SHAFT (BLUE station).
  - iv. Turn LOCKING BOLT E (2 places) counter-clockwise to loosen.
  - v. Turn ADJUSTMENT BOLT F clockwise 1/64 of a turn.
  - vi. Retighten all locking bolts/nuts.
  
- B.) **To correct for UP and INTO the fascia board:**  
Relieve pressure from the face side of the top #3 DRIVE FORMING ROLLER.
  - i. Turn locknut on ADJUSTMENT BOLT I counter-clockwise to loosen.
  - ii. Turn ADJUSTMENT BOLT I counter-clockwise 1/64 of a turn.
  - iii. Relieve pressure to the SWING SHAFT (BLUE station).
  - iv. Turn LOCKING BOLTS E clockwise to loosen.
  - v. Turn ADJUSTMENT BOLT F counter-clockwise 1/64 of a turn.
  - vi. Retighten all locking bolts/nuts.

➤ **NOTE:** After adjustment is made, run an 8' section of gutter to inspect.  
If more adjustment is needed, repeat procedure.

### 3. ADJUSTING THE WIDTH OF THE GUTTER

If gutter is too wide or narrow between lines #3 and #9: (SEE PG. 36)

1. Check lines #6 & #7 for being at a 90-degree angle to the bottom. (SEE PG. 36)  
For Adjustment (SEE PG. 25)
  - A.) **If less than a 90-degree angle is present:** Add pressure to bell wheel.
    - i. Turn LOCKING BOLT A and PIVOT BOLT B counter-clockwise to loosen.
    - ii. Turn ADJUSTMENT BOLT B clockwise a 1/16 of a turn.
  - B.) **If more than a 90-degree angle is present:** Relieve pressure to bell wheel.
    - i. Turn LOCKING BOLT A and PIVOT BOLT B counter-clockwise to loosen.
    - ii. Turning ADJUSTMENT BOLT B counter-clockwise a 1/16 of a turn.
  
2. If #6 and #7 are square to the bottom and the gutter is too wide or narrow. (SEE PG. 22)
  - A.) **If gutter is too wide:** Move **EXIT LIPBOX MOUNT** towards the back of gutter.
    - i. Loosen MOUNTING BOLTS (K)
    - ii. Loosen LOCKING NUT (L-2)
    - iii. Turn ADJUSTMENT BOLT (M-2) clockwise 1/16 of a turn.
    - iv. Tighten MOUNTING BOLTS (K) and LOCKING NUT (L-2)
  - B.) **If gutter is too narrow:** Move **EXIT LIPBOX MOUNT** away from the back of gutter.
    - i. Loosen MOUNTING BOLTS (K)
    - ii. Loosen LOCKING NUT (L-1)
    - iii. Turn ADJUSTMENT BOLT (M-1) clockwise 1/16 of a turn.
    - iv. Tighten MOUNTING BOLTS (K) and LOCKING NUT (L-1)

➤ **NOTE:** After adjustment is made, run an 8' section of gutter to inspect.  
If more adjustment is needed, repeat procedure.

4. **CONTINUOUS MARKS OR SCRATCHES**
  - a. Check for interference with shear.
  - b. Inspect guide rods for imperfections.
  
5. **MATERIAL SLIPPING: (MACHINE NOT PULLING MATERIAL THROUGH)**
  - a. Check the pressure on the spool shaft that is in use from the upright brakes.
  - b. Check that the entrance guides are not too tight or restricting the material.
    - i. If the guides are correct and the spools are unlocked, add pressure to the #1 & #2 drive assemblies (SEE PG. 18, SECTION 10).
    - ii. When metal slippage occurs while clearing machine and after metal is past the #2 drive, add equal pressure to the #3 DRIVE FORMING ROLLER (SEE PG. 24).
  
6. **OIL CANNING OR RIPPLING ON BOTTOM**
  - a. An imperfect bottom on the gutter is very uncommon from the IRONMAN.
    - i. Check all bottom rollers, drive rollers, and skate rollers for tape, debris, or buildup.
    - ii. Make sure top drive rollers are not past factory tolerance.

**GUTTER PROFILE  
VIEWED BETWEEN THE FACE BOX  
AND THE LIP BOX**

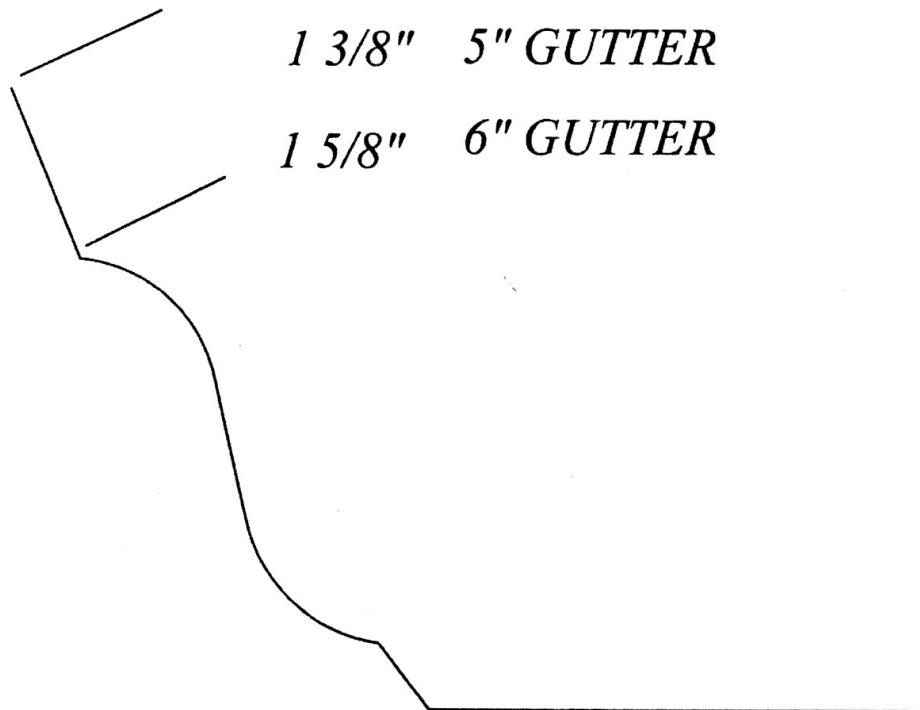

# PROFILE OF GUTTER

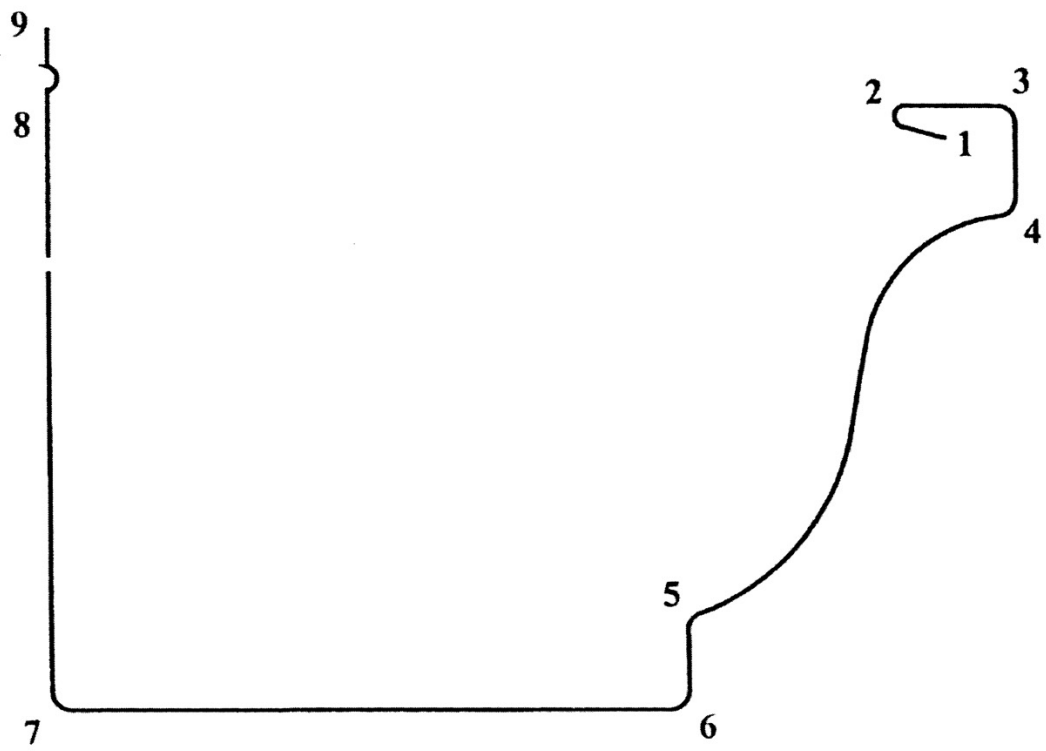



## NEW MACHINE WARRANTY

KWM GUTTERMAN, INC. Warrants the machine described in your invoice by serial number. The manufacturer will replace or repair any part or parts of the machine that are defective in workmanship or material manufactured by KWM Gutterman Inc. for a period of 36 months from the date of purchase. All Electrical components including but not limited to motor, relays, switches and buttons for a period of 12 months from the date of purchase. Claims under this warranty, are the sole option of the manufacturer.

The obligation under this warranty is limited to the replacement or repair of such parts defective in material or workmanship. This warranty does not cover failures found to have been caused by wear, damage, low voltage, abuse, misuse, accident or any procedures contrary to instructions set forth in the instruction manual. This warranty does not obligate the manufacturer to bear the cost of material used for adjustment, transportation charges or down time in connection with the replacement or repair of defective parts nor shall it apply to machine upon which repairs or alterations have been made unless authorized by KWM GUTTERMAN, INC.

KWM GUTTERMAN, INC. shall in no event be liable for consequential damage or contingent liabilities arising out of the failure of any machine or parts to operate properly.

KWM GUTTERMAN, INC. shall in no event be liable to bear costs of lost work, material, travel, or freight, caused by any part or parts of the machine that are defective in workmanship or material. All warranty work must be returned to 795 South Larkin Avenue, Rockdale, Illinois. Prior authorization must be obtained from KWM GUTTERMAN, INC. before any warranty work will be performed.

THE WARRANTIES SET FORTH HEREIN ARE IN LIEU OF ANY AND ALL OTHER WARRANTIES EXPRESSED OR IMPLIED. THE BUYER ACKNOWLEDGES THAT NO OTHER REPRESENTATIONS WERE MADE TO HIM OR RELIED UPON BY HIM WITH RESPECT TO THE QUALITY AND FUNCTIONS OF THE MACHINE.

KWM GUTTERMAN, INC.  
Phone (815) 725-9205. Fax (815) 725-4429  
795 South Larkin Avenue. Rockdale, Illinois 60436  
[www.kwmgutterman.com](http://www.kwmgutterman.com)



**Manufacturing the Best, Built to Stand the Test**

**795 South Larkin Avenue  
Rockdale, Illinois 60436**

**Phone (815) 725-9205**

**Fax (815) 725-4429**

**Toll-Free (888) 729-4290**

**E-mail [sales@kwmgutterman.com](mailto:sales@kwmgutterman.com)**

**[www.kwmgutterman.com](http://www.kwmgutterman.com)**